



**Wheels
Brakes
Landing gear
for Aircraft**

**Catalog 2016
English**



Indice C du 17 mai 2016

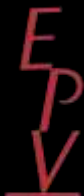

Quality and Performance since 1985

www.beringer-aero.com

1985 **Gilbert Béringer** created BERINGER Company. helped by his wife **Véronique**. He has been manufacturing wheels, forks and side cars for motorbikes, and then brakes, in the same spirit of quality and performance for 30 years. BERINGER braking products for motorbikes and cars have been accepted by the well-known racing teams for their exceptional reliability, allowing BERINGER to be used by many teams in the World Endurance Championships with many World Champion titles. This was all made possible by a team of exceptional mechanical engineers who have studied and developed new products whose performance/weight ratio is without precedent, for each specific use.

2002 **BERINGER Wheels & Brakes** was born, when Gilbert Béringer, also a pilot and aircraft builder fond of aviation, decided to apply his patented high performance braking solutions to the aeronautical world.

2007 **Rémi Béringer**, son of Gilbert and Véronique, joined the Company after he graduated as Mechanical Dipl. Engineer. Also fond of aviation, he designed with Gilbert most of the products dedicated to light-sport aircraft, Formula One Racers, gliders and various fast machines.

2009 BERINGER Company sold motorbike and car activities to focus on the development of wheels & brakes for aircraft. **BERINGER AERO** was born.

2011 BERINGER AERO moved to the airport of Gap-Tallard in the south of France, in a new building dedicated to aviation, with a direct access to the runway. This new plant consists of offices, workshops, and test room with the dyno and test benches designed by Rémi. A hangar welcomes the aircraft receiving the wheel & brake prototypes for the tests.

Claire Béringer, daughter of Gilbert and Véronique, joined the Company after she graduated as Aeronautical & Energy Dipl. Engineer (including 5 months at Oakland University–Detroit, MI) topped with a Master's degree in Commercial and Management Operations.

Marie, Christine, Brice have also joined the Company.

2012 **BERINGER AERO USA Inc.** was born in Chicago to answer the US customer needs. **Viviane Michaud**, also from Béringer's family, is in charge of the subsidiary.

2015 BERINGER celebrated the 30th anniversary of the Company. The **ALG landing gear** was designed to improve the safety of Taildragger Aircraft.

Leandro, Marie Luce and **Christian** joined the Company.

A FLYING FAMILY In the Béringer family, everybody flies: Gilbert, Véronique and Rémi fly their homebuilt tail dragger as well as gliders; and Claire flies gliders and ultralight Aircraft.

AN ADVANCED TECHNOLOGY

BERINGER makes wheels and braking systems for a wide range of aircraft, from light aircraft up to its now-standard STC for the Pilatus PC-6, and the Cirrus SR20/22 plus complete kits for many popular aircraft, that include everything for a bolt-on conversion. These innovations are covered by nine patents and have allowed BERINGER brakes to take a decisive technological lead. The new ALG undercarriage is covered by a patent.

QUALITY and CERTIFICATIONS

Of course, BERINGER® controls product quality to ensure total reliability to the users of wheels and brakes. This is evidenced by the Alternative Procedures to Design Organisation Agreement given by EASA in 2006 and by the Production Organisation Agreement given by DGAC in 2008.



Véronique Gilbert Claire Rémi Christine Brice Viviane (USA) Christian Marie Luce Leandro Marie

BERINGER AERO's commitment to sustainable development

Respect for the Environment

- At BERINGER, toxic substances and non recyclable materials are eliminated from the fabrication process
- Workshop trash is sorted prior to disposal.
- An environmental awareness campaign is in force and consistently reviewed.

Reduction of Energy Consumption

- Our specially-designed bioclimatic building (BBC) made of local wood only consumes only 10% of the energy required to heat or cool a conventional steel building.
- 98% of the energy used to heat our water is solar-powered
- BERINGER employs vehicles using propane (LPG): they have reduced CO2 emissions and have no particulate emissions.

Eco-Designs for Products

- BERINGER products are designed to have a virtually unlimited service life, because pieces that are worn down can be replaced.
- Components are 99% recyclable.
- 98% of the products are made in France, within a radius of 200 miles; this process reduces transportation and energizes local industrial bases.

Respect for Human Dignity in the Workplace

- From one end of the assembly line to another, from in-house to subcontractors, BERINGER staff members work in optimal conditions following the regulations of OIT (International Work Organization).
- BERINGER does not award contracts based on "lowest-cost," and does not use outsourcing.

Respect for the Ethics of Economics

- BERINGER partners (suppliers, subcontractors, banks, clients) are chosen based on ethical criteria, not only the lowest price
- BERINGER commits to projects based on their moral philosophy :
 - BERINGER wheels are not involved in projects that could intentionally threaten human life.
 - BERINGER has partnerships in eco-friendly projects (e.g., Green challenge, SolarImpulse).

Zero Compromise on Quality

At BERINGER, quality is not only respect for procedures that the EASA certifies, such as the Design Approval Organization and the Production Approval Organization (Part 21G). Quality is a pledge of trust to our clients: our clients entrust us with their lives. To remain worthy of this trust, we offer a life-time warranty (liability insurance) on materials and craftsmanship on all our products.

BERINGER AERO integrates its partners in its projects, from the design stage to commercialization

- AeroProviders : a group of suppliers for Light Aviation manufacturers
- PEGASE : innovation and development group of companies working for Aviation
- Hautes Alpes Développement: Development Agency for local companies In Hautes Alpes department (region) of France.



Since 2010 the MADE IN RESPECT label has been recognizing BERINGER AERO's commitment to sustainable development

made in
respect®
LE LABEL DE DEVELOPPEMENT DURABLE



On February 34, 2012, BERINGER AERO won the Trophée RSE PACA TPE (Social Responsibility of the Companies).

INDEX

Page

<i>BERINGER Company - History - Sustainable development</i>	2-3
<i>FAQ</i>	5
<i>HOW TO CHOOSE the correct wheels, tires and brakes ?</i>	7-8
<i>They have chosen BERINGER as original equipment</i>	45-46
<i>Tribute to BERINGER 2015 champions</i>	43-44
ANTI-SKID - ALIR system - pressure regulators	35-36
BRAKE FLUID - information	6
BRAKE FLUID RESERVOIRS	32
BRAKING SYSTEM - braking schematic (symmetrical and differential)	34 & 37
BUSH FLYING equipment	17-18
CERTIFIED WHEELS & BRAKES	15-16
HOSE - HOSE FITTINGS - «to be screwed» and «factory assembled»	38-39
LANDING GEAR ALG	18
LEVER MASTER CYLINDERS - hand operated - cable operated	30 & 31
LIST of WHEEL & BRAKE complete SETS (sorted by type of Aircraft)	9-14
MASTER CYLINDERS	27-31
MASTER CYLINDERS FOR CONTROL STICK	33
NOSE WHEELS	9 & 22
PARKING BRAKE VALVE	36
PRESSURE REGULATORS - LIMITERS	34-36
SPARE PARTS	40-41
TAILWHEELS	9 & 22
TAIL WHEEL groundloop-resistant GLR	17
TIRES	25-26
TOOLS - bleeder - brake fluids	42
WHEEL AXLES	23-24
WHEELS without brake : Nose wheel - Tailwheel	22
WHEELS & BRAKE ASSEMBLIES - wheel/caliper/disc/pad	18-19-20

CAN'T FIND WHAT YOU NEED ? LET US HELP

Technical or sales support: Tel **+33 (0) 492 201 619** Fax **+33 (0) 492 526 966**

Commercial e-mail sales@beringer-aero.com order e-mail production@beringer-aero.com

Company hours : Mon. - Fri. : 8.30-12.30 am and 01.30-6.00 pm

Postal address: **BERINGER AERO - Aéroport - 05130 Tallard - France**

WARNING: the mounting and the maintenance of the wheels and brakes must be done by an authorized BERINGER SERVICE CENTER (and by a certified Part 145 workshop for certified aircraft). BERINGER Company is not responsible of troubles due to a wrong mounting, not in accordance with BERINGER instruction (available on our website) and with State of the Art.

CAUTION: BERINGER® and AEROTEC® are registered trademarks.

BERINGER® owns 9 different world patents protecting its unique technology on master cylinders, calipers, discs, brake regulators and aircraft wheels.

INFRINGERS WILL BE PROSECUTED

? How can I order BERINGER parts

- You can order through the BERINGER network as listed from the website.
- Call us or send an e-mail at contact@beringer-aero.com at any time and we will return some ideas.

? I have a technical question. Who can help?

- Our Service Centers are able to answer many technical questions, but for a precise technical or engineering question, please contact BERINGER directly.

? Why are most BERINGER wheels made for tubeless tires?

- Tubeless has many advantages compared to tube type:

- safer (less risk of puncture)
- weight saving (a tube weights around 1 to 2 lbs)
- cost effective (no tube means no tube to buy)

These are the same reasons why nowadays you find tubeless wheels on cars, motorcycles, and all commercial airplanes. Tubeless designs have specific features to be airtight (most designs use o-rings) and precise machining to ensure proper contact between tire and wheel.

? How can I choose the correct wheels, tires and brakes?

1. First, select your tires according to your use: What kinds of runways: grass, concrete, rough?
2. Match the wheel to the tires. (See our tire-wheel application chart in the catalog.)

The brakes you need will depend mostly on the weight of the aircraft and the landing speed, though tire size can come into play at the extremes of the size ranges: to get close, use the formula to calculate the Kinetic energy needed (see the catalogue page 8). Many popular setups are already listed p.9-14.

? How do I know the type of brake fluid to fill my brake system?

- The type of brake fluid to use is most of the time written directly on the brake caliper and on m. cyls. DOT4 usually has yellow to amber color and MINERAL (“Mil spec” or “aviation”) brake fluid is red. If you have any doubt please contact your BERINGER SERVICE CENTER.

? I filled my brake system with the wrong brake fluid: what can I do?

- The wrong brake fluid will damage the seals after only few minutes of contact. This is potentially dangerous because after a short period your brakes can lock, leak or stop working properly. If you have put the wrong fluid into the system, you will have to change all the seals of the entire system. (Note: this is true, regardless which brand of brake parts you use.) If you have a BERINGER system, ask BERINGER for repair kits or send the parts back to BERINGER service for repair.

? If I switch to BERINGER Wheels & Brakes do I also need to change my M. Cylinders?

- If they are compatible with the brake fluid then you still need to check the hydraulic ratio: with our brakes we recommend using M. Cyl.s with a piston bore of 1/2" (9/16" maximum). If the bore of the M. Cyl.s is too big, they cannot produce enough pressure to provide enough braking torque on the wheels. Some master cylinders are so crude (or just so old) that the inherent smoothness and feel of BERINGER calipers can be masked in operation; for this reason, we recommend using only BERINGER master cylinders.

? I want to improve my Wheel & Brake system but BERINGER prices are too high.

- BERINGER systems are a little more expensive than ordinary products but thanks to their exceptional reliability and life, the operating cost is much more economical. It is often possible to pay back your investment in 1 or 2 years, with brake components that last, lines that don't leak, pads that have 3-5 times the life of legacy pads, quicker and simpler pad replacements, no tube expenses, no bearing maintenance, and (with ALIR), fewer flat-spotted tires and straighter, shorter stops. And all that time, you are enjoying better, smoother braking. (And BERINGER wheels save weight and look good, too.)

Brake fluid is critical to the function and performance of your brake system. Choosing the right brake fluid will insure trouble free functioning for many years. Conversely, the wrong brake fluid will damage seals and cause failure of your brake system. There are two predominant “families” of brake fluid in use worldwide:



A. The first family is polyethylene-glycol based and is compatible with only EPDM seals.

These fluids have been developed for the hydraulic brakes of motor vehicles and are called DOT3, DOT4, DOT5 or DOT5.1

DOT3 has lower performance and has been replaced by DOT4. DOT4 is the most commonly used fluid in motor vehicles. DOT5 is usually silicone-based, but is not commonly used, and is not miscible (“mixable”) with DOT3 or DOT4. DOT5.1 is not miscible with DOT5 and may also be not miscible with DOT3 or DOT4.

The primary objection to DOT 3 and 4 fluids was that they are hygroscopic (they absorb water). However, in a sealed reservoir, in a corrosion-resistant brake system, DOT4 fluids will remain usable for minimum 10 years. Additionally DOT3 and 4 brake fluids are aggressive with paint. Continent systems and care in handling remove this negative.

In the “DOT” family, we recommend using DOT4 and only DOT4 because the performance is adequate, and all DOT4 brands are miscible with each other.

DOT4 is used on many ultralight aircraft. You can purchase DOT4 almost everywhere around the globe as it is used on all recent cars and most motorcycles.



B. The second family is mineral-oil based and compatible with only* NBR (Nitrile) seals.

The hydraulic fluid MIL-H-5606 has been commonly used in general aviation for many years.

The major deficiencies of MIL-H-5606 are its high flammability and a relatively low boiling point.

In the ”mineral” or “MIL” family we recommend using the MIL-PRF-87257 as a replacement of the MIL-H-5606. These 2 fluids are compatible and miscible with each other. MIL-PRF-87257 is fire resistant and synthetic-hydrocarbon based, it has also a higher boiling point than MIL-H-5606.

FLUID	FLUID Color	SEALS	
		EPDM	NBR (Nitrile)
DOT4	colorless to amber	ok	Not compatible
MIL-H-5606	red	Not compatible	ok
MIL-PRF-87257	red	Not compatible	ok

***NBR (Nitrile) seals → mineral fluid → red color → MIL-PRF-87257 recommended
EPDM seals → DOT4 brake fluid → colorless to amber color → DOT4 only***

Notes:
EPDM seals are very sensitive to petroleum based solvents: few minutes of contact can completely damage the EPDM seals. That is why we recommend cleaning the parts only with a dry cloth or soap and water.

* These fluids may be compatible with other seal materials (contact us for more information)

BERINGER WHEELS and BRAKES for main gear are designed to provide the best stopping power and the reliability you are expecting from a safe braking system. We will help you to choose the dimension and brake torque adapted to your aircraft. We have a large range of assemblies: wheel / brake caliper / brake pad / brake disc. We also design and manufacture the optimal upstream components: reservoirs, master cylinders, the ALIR anti-skid system, and parking brakes. All these are tied together with top-quality braided stainless steel Teflon lines and proper fittings. Components and complete systems are available.



BERINGER WHEELS: advanced technology

- High strength aluminum alloy CNC machined from solid, anodized for optimal corrosion resistance
- TUBELESS wheel with O-rings and rigid valve
- SEALED BALL BEARINGS for optimal durability: greased for life, no maintenance
- Very low rolling resistance

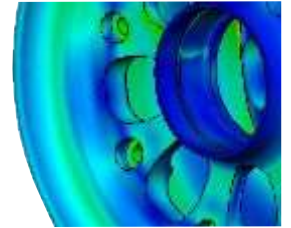

FEM calculated and checked

During the design of a wheel we focus on three criteria: strength, weight, and durability. First, we assess the overall design and apply our experience and some hand calculations. Then we build a 3D model on CAD software and run FEM (finite element analysis) in the optimizing process, where we remove material from one side to add it on another, etc... till the result is satisfying for us with an optimized strength/weight ratio.



Hydraulic press
44,000 lbs

Then we make prototypes and start the qualifying process on our own bench machines.

The **BERINGER R&D laboratory** is dedicated to Research, Development and Certification tests.

On the wheel itself we do 3 different tests :

- **Load test:** we apply different loadings on the wheel and tire (radial and side load) to check the strength and load rating of the wheel. Ultimate load tests go up to 6 times the static load using our 40,000lb hydraulic press capacity.
- **Pressure test:** mounted tire is inflated with water up to 3.5 times the maximum inflation pressure to check bolts' strength and wheel stiffness.
- **Roll test :** wheel is pressed on a rotating drum for 1000 miles at maximum static load to detect eventual fatigue problems or bearing failure, etc...

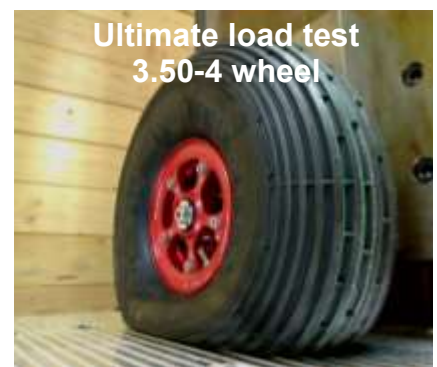

Ultimate load test
3.50-4 wheel



Ultimate load test
11.00-12 wheel

When the wheel has passed all the tests then we install the wheel on an aircraft for ground and flight checks.

Note: when the wheel's design work for the Solar Impulse was occurring, BERINGER's proprietary dynamometer was employed, because of the BERINGER wheel' strength and our dyno's exceptional ability to load and measure the tire. On the aircraft, that tire and its Beringer wheel (5.00-5) were of course run tubeless, at a pressure of 10 bar (over 140psi) and a static load of 3,850lbs (2.7 times more than rated load).



BRAKE CALIPERS:

- Covered by AEROTEC® Patents
- 2 or 3 stainless steel polished pistons
- Body made of aerospace alloy to withstand high temperatures (>200Mpa at 200°C)
- Available for DOT4 fluid OR for MINERAL (MIL FLUID) (seals are different; specify and never mix)
- 2 inputs, thread size M10x1
- Full metallic brake pads (no rivets) for extended life



BRAKE DISCS:

- Covered by AEROTEC® Patents
- Stainless steel disc or high strength steel disc with coating
- Brake discs are made of highest quality material for thermal stability and long life



Many tests are done to certify brake calipers and discs. One of those tests is the dynamic torque test; for this test we use our dynamometer. The kinetic energy capacity is tested with this machine. The dyno allows us to push the brake system to its limits. Many sensors are installed to measure temperatures. All these tests are performed to ensure the total safety and reliability of the brake system.

Kinetic energy values indicated in the next pages are not only calculated but measured and checked on real tests.

The endurance test is also a proof of quality and durability. The purpose of this test is to verify the life of the parts. The certification test requires 100,000 cycles at maximum operating pressure, but we test our parts to a minimum 200,000 cycles. This represents more cycles than the brake system will be subjected to in the entire aircraft life.



How to choose your wheel & brake system:

- Select the size of tire that you need
- Then select the wheel size required for this tire (use our application chart page 24)
- Check the static load rating: this is the weight on each wheel (at maximum static aircraft weight) that the wheel is capable of supporting.
- Check the kinetic energy rating : the first function of a brake system is to transform aircraft kinetic energy into heat. This heat is absorbed and dissipated mostly by the disc (a thicker disc will absorb more heat energy).

The kinetic energy required to stop an aircraft is a function of the mass of the aircraft and its landing speed. You can calculate the kinetic energy requirement of your aircraft by using the following formula:

$$\text{Kinetic Energy [FT-LBS]} = \frac{0.044 \times W \times V^2}{N}$$

W = Gross weight (lbs)

V = Braking speed (kts)

N = Number of wheels with brakes

The kinetic energy values shown in the chart on page 14 are maximum values in case of an RTO (Rejected Take Off). This RTO value should be 30% higher than the value calculated above.

If you are not sure what system is right for your aircraft, give us a call.

WHEELS & BRAKES - COMPLETE KITS

Installing BERINGER wheels and brakes on your Aircraft increases a lot the performance and improves your safety.

- **Weight saving and no risk of cracking** >> the wheels and calipers are fully CNC machined from aeronautical aluminum alloy. This manufacturing process gives 2 to 3 times more strength than cast wheels and prevents any risk of cracking. You save 3 to 5kg depending on your original brake system
- **Rolling distance dramatically reduced** >> increased safety level - landing on most airfields
- **High efficiency combined with easy landing** >> progressive rise in performance, no wheel locking thanks to the regulator or limiter
- **Tubeless wheels** >> less risk of bursting - can be used everywhere: on seal, grass and rough terrain (*tube mounting possible in case of emergency*)
- **Maintenance free hydraulic line** >> the circuit is sealed, it does not leak and suit aerobatic airplanes
- **Extended braking disc and pad life** >> BERINGER products are reliable and they are designed to last longer. The bearings are sealed and do not need maintenance. The aluminum parts are anodized for corrosion resistance.

You will find pages 11-14 the table of the complete main wheel and brake sets. They are designed to mount directly, replacing original equipment. Brake calipers use sintered metallic pads and stainless steel discs (except specifications) for increased life. Concerning homebuilt Aircraft, we recommend to read the FAQ page 5 that will guide you to chose the suitable parts.

MAIN WHEELS: the wheel & brake kits includes:

- Main wheels with calipers and discs
- Tires (mounted and pressure tested)
- Axles or adaptation parts (as required)
- Master brake cylinders & fluid reservoirs
- A parking brake valve (not always included)
- An anti-lock regulator or pressure limiter
- Stainless steel brake lines and fittings
- Detailed mounting instructions

The composition of the kits may vary depending on the Aircraft Type. (For example kits for Van's do not include the reservoirs nor the regulators).

ALIR anti-lock system: a real advance in terms of safety

Most kits include the ALIR anti-lock regulator allowing to brake in-line and to avoid wheel locking.

**ALIR System
Anti Lock In line
Regulator**

NOSE WHEEL: the nose wheel kit includes:

- A tubeless nose wheel with the tire (mounted on rim, pressure tested)
- An aluminum axle with bearing spacer

The composition of the kits may vary depending on the Aircraft Type.

TAILWHEEL: we recommend the GLR tailwheel, groundloop-resistant developed to increase the safety when you take off and you land.

The GLR is available for taildraggers up to 1500lbs . It features a robust design for rough airstrips. (*complete description page 17*).

Two types are available:

Tailwheel complete system including wheel and tire 2.80/2.50-4" (weight 3.77kg) = **1065 € P/N TW-001**
BUSH tailwheel complete system including wheel and tire 4.00-4" (weight 4.12kg) = **1280 € P/N TW-002**

.../...

**TUBELESS
WHEELS**



**PATENTED
groundloop-
resistant
tailwheel**

WHEELS & BRAKES - COMPLETE KITS

We also propose retrofit tailwheel kits to fit original mounting.

The tailwheel kit includes:

- A tubeless tailwheel with the tire (mounted on rim, pressure tested)
- An aluminum axle with bearing spacer

The composition of the kits may vary depending on the Aircraft Type.

Tailwheel
Scott
replacement



OPTION: Copilot brakes - Parking brake valve - Wheel caps - Amphibian use - Skis mounting

Depending on the aircraft, you will find in the table of the complete sets that is following next page, the option available. In most cases, the option is not included in the wheel and brake kit.

The copilot brake option includes:

the master cylinder (s) for the copilot seat + ends + hydraulic fittings + 1,50m hose (see the table of the complete kits).

The Parking brake valve option includes:

the parking valve + fittings + 1m hose.

On hand master cylinder HAB02, the parking pin is included (see the table of the complete kits).

The wheel cap option includes:

two wheel caps according to your wheel dimension and the screws if required (see the table of the complete kits).

Copilot brakes



Cap on 6" wheel



Parking brake valve

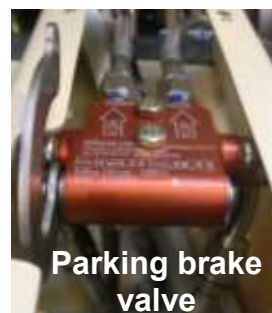

P/N	OPTION	List of parts included in the OPTION	Price
INOBE	Amphibian use	Two stainless steel bearings for one wheel	134
FUS-013	Datum ski option	Two special axles for 4.00-6 wheels - Datum skiS installation (only for axles T1-T2-T4-T5)	134 (each axle)

The Amphibian use option includes: two stainless steel bearings for one wheel.

P/N INOBE price 134€

The Datum skis option:

this option allows the mounting of DATUM skis on a BERINGER 4.00-6" wheel. It includes two special axles.

It is available only for axle template T1-T2-T4-T5.

P/N SKI01 price 134€



Parking brake pin



Tires included in the kits are standard ones. Contact us for specific use or other dimensions. The type of your airplane is not indicated in the table of kits available? We may still have it. Please contact us.

WE RECOMMEND FIRST MOUNTING OF TIRES ON WHEELS IN OUR PLANT. This service, free of charge, includes a pressure test, ensuring maximum security of the assembly.

FINISH : Red anodizing is standard color for wheels, brakes and master cylinders.

Calipers are ALWAYS red. Other colors can be available for certain wheels on special order with an extra delay at an additional cost of **85€** per batch of parts. **WARNING: Colors may vary.**

WHEELS & BRAKES - COMPLETE KITS

Aircraft Type	Manufacturer	Wheel Ø	Tires	Braking controls	Mains Kit P/N	Price	Nose/Tail wheel Ø	Tire	Nose/Tail wheel Kit P/N	Price	Copilot Brake P/N	Price	Parking valve P/N	Price	Main wheel Cap P/N	Unit Price
Arcus	Schempp H.	5"	380x150-5	Cable operated M. Cyl. HAC01	SCH02	-	-	-	-	-	-	-	-	-	-	-
ASW17	Schleicher	5"	5.00-5	Hand operated M. Cyl. HAB01	-	-	-	-	-	-	-	-	-	-	-	-
ASW20	Schleicher	5"	5.00-5	Hand operated M. Cyl. HAB01	STC-005*	1008	-	-	-	-	-	-	-	-	-	-
ASW22	Schleicher	5"	5.00-5	Hand operated M. Cyl. HAB01	-	-	-	-	-	-	-	-	-	-	-	-
Avid Flyer	Avid	6"	15x6.00-6	Hand operated M. Cyl. HAB02	SAF02	1817	-	-	-	-	-	-	-	-	BCH-003	24
B-400	Breezer	5"	5.00-5	M. Cyl. MP-002	SBR01	1944	5"	5.00-5	SBR01A	532	COP01	409	PKG01	256	BCH-002	24
Bonus	Test	5"	5.00-5	Hand operated M. Cyl. HAB02	STB01	1370	-	-	-	-	-	-	Included	-	-	-
Bücker Jungmann	Air Res	6"	6.00-6	M. Cyl. MP-002	SBJ01	2701	-	-	-	-	COP01	409	PKG01	256	BCH-004	45
C42 (retrofit)	COMCO Ikarus	6"	4.00-6	Hand operated M. Cyl. HAB02	SCC01	1536	4"	4.00-4	SCC01A	247	-	-	Included	-	BCH-003	24
Century	Storm Aircraft	5"	11x4.00-5	Hand operated M. Cyl. HAB02	STR01	1428	-	-	-	-	COP04	303	Included	-	BCH-002	24
Cheetah XLS	Aerosport	6"	4.00-6	Hand operated M. Cyl. HAB02	SCX01	1764	-	-	-	-	COP04	303	Included	-	BCH-003	24
Coyote S6	Rans	6"	15x6.00-6	M. Cyl. MP-003	SRA02	1867	-	-	-	-	COP02	390	PKG01	256	BCH-002	24
Coyote S6 1st type	Rans	6"	15x6.00-6	M. Cyl. MP-003	SRA01	1983	-	-	-	-	COP02	390	PKG01	256	BCH-002	24
Cozy	Rutan	5"	5.00-5	M. Cyl. MP-003	SLC05	2280	-	-	-	-	COP02	390	PKG01	256	BCH-002	24
CTSW (2007)	Flight Design	6"	15x6.00-6	M. Cyl. MP-002	SFD01	1624	-	-	-	-	-	-	PKG01	256	BCH-003	24
DA40 NG Tundra	Diamond Aircraft	6"	8.50-6	Included in STC	STC-009	*	6"	6.00-6	Included in STC	Included in STC	Included in STC	-	-	-	BCH-004	45
DA42	Diamond Aircraft	6"	15x6.00-6	Included in STC	STC-013.1	5669	5"	5.00-5	Included in STC	Included in STC	Included in STC	-	-	-	-	-
DA42 NG	Diamond Aircraft	6"	15x6.00-6	Included in STC	STC-013.2	5669	5"	5.00-5	Included in STC	Included in STC	Included in STC	-	-	-	-	-
Discus 2A	Schempp H.	5"	11x4.00-5	Cable operated M. Cyl. HAC01	STC-007*	1019	-	-	-	-	-	-	-	-	-	-
Duo Discus	Schempp H.	5"	380x150-5	Cable operated M. Cyl. HAC01	SCH02	-	-	-	-	-	-	-	-	-	-	-
Dynamic WT9 Club FG	Aerospool	6"	15x6.00-6	M. Cyl. MP-002	SAE02	1746	6"	13x5.00-6	SAE02A	391	-	-	PKG01	256	-	-
Dynamic WT9 Speed RG	Aerospool	6"	15x6.00-6	M. Cyl. MP-002	SAE01	1843	6"	13x5.00-6	SAE01A	391	-	-	PKG01	256	-	-
Edge 540	Zivko	5"	5.00-5	M. Cyl. MP-003	SED01	2152	-	-	-	-	COP02	390	PKG01	256	-	-
Eife S4	Neukom	5"	11x4.00-5	Hand operated M. Cyl. HAB02	-	-	-	-	-	-	-	-	-	-	-	-
Ellipse	A2CZ	6"	15x6.00-6	M. Cyl. MP-002	SEL01	1492	6"	13x5.00-6	SEL01A	391	-	-	PKG01	256	BCH-003	24
Europa monowheel	-	6"	7.00-6	Hand operated M. Cyl. HAB02	SEU02	1472	-	-	-	-	-	-	Included	-	-	-
Eurostar	Evektor	6"	15x6.00-6	M. Cyl. MP-002	SEU01	1795	6"	13x5.00-6	SEU01A	391	COP01	409	PKG01	256	BCH-003	24
Extra 300 1-seater	Extra	5"	5.00-5	Included in STC	STC-012.1	2490	-	-	-	-	-	-	-	-	-	-
Extra 300 2-seater	Extra	5"	5.00-5	Included in STC	STC-012.2	2850	-	-	-	-	Included in STC	-	-	-	-	-
Faeta	Atec	6"	4.00-6	Hand operated M. Cyl. HAB02	SAF01	1535	4"	4.00-4	SAF01A	247	-	-	Included	-	BCH-003	24
Falco	-	5"	5.00-5	M. Cyl. MP-003	SFA01	2219	5"	11x4.00-5	SFA01A	369	COP02	390	PKG01	256	BCH-002	24
FK Mark I, II, III FK14	FK Lightplanes	6"	4.00-6	Hand operated M. Cyl. MP-004.5	SFK02	1678	4"	4.00-4	SFK02A	247	-	-	PKG01	256	BCH-003	24
FK Mark IV - ELA	FK Lightplanes	6"	4.00-6	Hand operated M. Cyl. MP-004.5	SFK01	1678	4"	4.00-4	SFK01A	247	-	-	PKG01	256	BCH-003	24

WHEELS & BRAKES - COMPLETE KITS

Aircraft Type	Manufacturer	Wheel Ø	Tires	Braking controls	Mains Kit P/N	Price	Nose/Tail Wheel Ø	Tire	Kit P/N	Price	Copilot Brake P/N	Price	Parking valve P/N	Price	Main wheel Cap P/N	Unit Price
FK 12	FK Lightplanes	6"	4.00-6	M. Cyl. MP-002	SFK03	1881	-	-	-	-	COP01	409	PKG01	256	BCH-003	24
Furio	Falcomposite	5"	5.00-5	M. Cyl. MP-003	SFU01	2307	5"	5.00-5	SFU01A	532	COP02	390	PKG01	256	BCH-002	24
G1	G1 Aviation	6"	15x6.00-6	Hand operated M. Cyl. HAB02	SGA01	1701	6"	15x6.00-6	SGA01A	391	COP04	303	Included	-	BCH-002	24
Gaz'Aile	-	5"	11x4.00-5	Hand operated M. Cyl. HAB02	SGZ01	1624	4"	4.00-4	SGZ01A	247	COP04	303	Included	-	BCH-002	24
Genev-01	Genevation	5"	5.00-5	M. Cyl. MP-002	SGE01	2299	-	-	-	-	COP01	409	PKG01	256	BCH-002	24
Glasair III - RLG	Glasair	5"	5.00-5	M. Cyl. MP-003	SGL02	2252	5"	11x4.00-5	SGL01A	369	COP02	390	PKG01	256	BCH-002	24
HPH 304S	HPH	5"	5.00-5	M. Cyl. MP-002	SHP01	847	-	-	-	-	-	-	-	-	-	-
J170	Jabiru	6"	4.00-6	M. Cyl. MP-002	SJU03	1542	6"	4.00-6	SJU03A	391	-	-	PKG01	256	BCH-003	24
J170	Jabiru	6"	4.00-6	Hand operated M. Cyl. HAB02	SJU04	1710	6"	4.00-6	SJU04A	391	-	-	Included	-	BCH-003	24
J400/J430	Jabiru	5"	5.00-5	M. Cyl. MP-002	SJU01	1937	6"	4.00-6	SJU01A	391	-	-	PKG01	256	BCH-002	24
J400/J430	Jabiru	5"	5.00-5	Hand operated M. Cyl. HAB02	SJU05	1937	6"	4.00-6	SJU05A	391	-	-	Included	-	BCH-002	24
Jodel D20 ULIM	-	5"	5.00-5	M. Cyl. MP-002	SJD01	1795	-	-	-	-	COP01	409	PKG01	256	BCH-002	24
Jonker JS1	Jonker Sailpl.	5"	5.00-5	M. Cyl. MP-003	JON02	1042	-	-	-	-	-	-	-	-	-	-
Junior	Ekolot	6"	4.00-6	Hand operated M. Cyl. HAB02	SEK01	1660	6"	4.00-6	SEK01A	247	COP04	303	Included	-	BCH-003	24
LAK-17A	UAB	5"	5.00-5	Hand operated M. Cyl. HAB02	STC-011	1019	-	-	-	-	-	-	-	-	-	-
LAK-17B	UAB	5"	5.00-5	Hand operated M. Cyl. HAB02	SLA02	979	-	-	-	-	-	-	-	-	-	-
Lambada	Distar	6"	4.00-6	Hand operated M. Cyl. HAB02	SLA01	1536	-	-	-	-	COP04	303	Included	-	BCH-003	24
Lancair 320/360 RLG	Lancair	5"	11x4.00-5	M. Cyl. MP-003	SLC04	2022	5"	11x4.00-5	SLC04A	369	COP02	390	PKG01	256	BCH-002	24
Lancair Legacy RLG	Lancair	5"	5.00-5	M. Cyl. MP-003	SLC01	2280	5"	5.00-5	SLC01A	366	COP02	390	PKG01	256	BCH-002	24
Libelle H201	Glasflügel	5"	11x4.00-5	Hand operated M. Cyl. HAB02	SLI01	1019	-	-	-	-	-	-	-	-	-	-
Long'Ez	Rutan	5"	5.00-5	M. Cyl. MP-003	SLE01	2190	-	-	-	-	-	-	PKG01	256	BCH-002	24
M16/22	Magni Gyro	6"	4.00-6	Cable operated M. Cyl. MP-004.1	SMG01	1570	4"	4.00-4	SMG01A	247	-	-	PKG01	256	BCH-003	24
M16/22 Reinforced	Magni Gyro	6"	4.00-6 +PAD03	Cable operated M. Cyl. MP-004.1	SMG03	1601	4"	4.00-4	SMG03A	247	-	-	PKG01	256	BCH-003	24
M16/22 Tundra	Magni Gyro	6"	6.00-6	Cable operated M. Cyl. MP-004.1	SMG02	1687	6"	4.00-6	SMG02A	247	-	-	PKG01	256	BCH-003	24
M24	Magni Gyro	6"	4.00-6	Cable operated M. Cyl. MP-004.1	SMG04	1570	4"	4.00-4	SMG01A	247	-	-	PKG01	256	BCH-003	24
M24 Reinforced	Magni Gyro	6"	4.00-6 +PAD03	Cable operated M. Cyl. MP-004.1	SMG06	1601	4"	4.00-4	SMG03A	247	-	-	PKG01	256	BCH-003	24
M24 Tundra	Magni Gyro	6"	6.00-6	Cable operated M. Cyl. MP-004.1	SMG05	1687	6"	4.00-6	SMG02A	247	-	-	PKG01	256	BCH-003	24
MCR01 hand brake Blade LG	Aupa Dynaero	5"	11x4.00-5	Hand operated M. Cyl. HAB02	SDY02	1647	4"	4.00-4	SDY02A	247	COP04	303	Included	-	BCH-002	24
MCR01 rudder brake Blade LG	Aupa Dynaero	5"	11x4.00-5	M. Cyl. MP-002	SDY03	1803	4"	4.00-4	SDY03A	247	-	-	PKG01	256	BCH-002	24
MCR01 rudder brake Oleo LG	Aupa Dynaero	5"	11x4.00-5	M. Cyl. MP-002	SDY01	1803	4"	4.00-4	SDY01A	247	-	-	PKG01	256	BCH-002	24
MiniLAK	UAB	4"	4.00-4	Hand operated M. Cyl. HAB01	SLA03	775	-	-	-	-	-	-	-	-	-	-
MXS	MX Aircraft	5"	5.00-5	M. Cyl. MP-003	SMX01	2152	-	-	-	-	-	-	-	-	BCH-002	24

WHEELS & BRAKES - COMPLETE KITS

Aircraft Type	Manufacturer	Wheel Ø	Tires	Braking controls	Mains Kit P/N	Price	Nose/ Tail Wheel Ø	Tire	Mains Kit P/N	Price	Copilot Brake P/N	Price	Parking valve P/N	Price	Main wheel Cap P/N	Unit Price
NG4	Rokospol	5"	5.00-5	M. Cyl. MP-002	SMS01	1817	-	-	-	-	COP01	409	PKG01	256	BCH-002	24
Nimbus 3 and 4	Schempp Hirth	5"	380x150-5	Cable operated M. Cyl. HAC01	SCH03	-	-	-	-	-	-	-	-	-	-	-
Nord1200-1201-1202-1203	Norércin	6"	6.00-6	M. Cyl. MP-002	SNR01	2255	5"	5.00-5	SNR01A	532	COP01	409	PKG01	256	BCH-004	45
Nynja	BestOff Air.	6"	4.00-6	Hand operated M. Cyl. HAB02	SSK01	1720	6"	13x5.00-6	SSK01A	391	COP04	303	Included	-	BCH-003	24
Nynja - VLA LG	BestOff Air.	6"	4.00-6	Hand operated M. Cyl. HAB02	SSK03	1590	6"	13x5.00-6	SSK01A	391	COP04	303	Included	-	BCH-003	24
P2002	Tecnam	5"	5.00-5	M. Cyl. MP-003	STP05	1568	6"	4.00-6	STP05A	391	COP02	390	PKG01	256	BCH-002	24
P2008	Tecnam	5"	5.00-5	M. Cyl. MP-003	STP02	2232	5"	5.00-5	STP02A	532	COP02	390	PKG01	256	BCH-002	24
P92 5" (school use)	Tecnam	5"	5.00-5	M. Cyl. MP-003	STP01	1644	6"	4.00-6	STP01A	391	-	-	PKG01	-	BCH-002	-
P92 6" (standard use)	Tecnam	6"	4.00-6	M. Cyl. MP-003	STP03	1437	6"	4.00-6	STP03A	391	-	-	PKG01	256	BCH-003	24
P96	Tecnam	5"	5.00-5	M. Cyl. MP-003	STP04	1568	6"	4.00-6	STP04A	391	-	-	PKG01	256	BCH-002	24
PC-6 10"	Pilatus	10"	-	Included in STC	STC-002.4	14239	4"	5.00-4	Included in STC	-	-	-	-	-	Included	-
PC-6 10" copilot brakes	Pilatus	10"	-	Included in STC	STC-002.3	15259	4"	5.00-4	Included in STC	-	Included in STC	-	-	-	Included	-
PC-6 12"	Pilatus	12"	-	Included in STC	STC-002.1	17239	4"	5.00-4	Included in STC	-	-	-	-	-	Included	-
PC-6 12" copilot brakes	Pilatus	12"	-	Included in STC	STC-002.2	18259	4"	5.00-4	Included in STC	-	Included in STC	-	-	-	Included	-
Pégase	Centrair	5"	5.00-5	Hand operated M. Cyl. HAB02	STC-003*	1008	-	-	-	-	-	-	-	-	-	-
Phenix	Phenix Aero	6"	4.00-6	Hand operated M. Cyl. HAB02	SPH01	1463	-	-	-	-	-	-	Included	-	BCH-003	24
Pioneer 200/300	Alpi Av.	6"	4.00-6	M. Cyl. MP-002	SPI01	1785	4"	4.00-4	SPI01A	247	-	-	PKG01	256	BCH-003	24
Pioneer 400	Alpi Av.	5"	5.00-5	M. Cyl. MP-002	SPI02	1785	5"	5.00-5	SPI02A	532	COP01	409	PKG01	256	BCH-002	24
Pitts S1	Aviat Air.	5"	5.00-5	M. Cyl. MP-003	SPT01	1965	-	-	-	-	-	-	PKG01	-	BCH-002	-
Prime	Blackshape	6"	4.00-6	M. Cyl. MP-002	SBL01	1218	4"	3.00-4	SBL01A	247	COP01	409	PKG01	-	BCH-003	24
Robin DR400	Robin A.	-	-	-	STC-006	1288	-	-	-	-	-	-	-	-	-	-
RV3	Van's A.	5"	11x4.00-5	M. Cyl. MP-002	SRVCO03	2009	-	-	-	-	-	-	PKG01	256	BCH-002	24
RV6-7-8-9-10 fuselage kit = pilot brakes	Van's A.	-	-	M. Cyl. MP-002	SRVFO1	634	-	-	-	-	-	-	-	-	-	-
RV6-7-8-9 finishing kit = main wheels + tires + axles	Van's Aircraft	5"	5.00-5	-	SRVFI02	1559	5"	11x4.00-5	SRV02A	369	-	-	-	-	BCH-002	24
RV6-7-8-9-10 fuselage kit = pilot brakes + parking v.	Van's Aircraft	-	-	M. Cyl. MP-002	SRVFO3	899	-	-	-	-	-	-	Included	-	-	-
RV6-7-8-9-10 fuselage kit = pilot/ co-pilot brakes + parking v.	Van's Aircraft	-	-	M. Cyl. MP-002	SRVFO4	1379	-	-	-	-	Included	-	Included	-	-	-
RV6-7-8-9-10 fuselage kit = pilot/ co-pilot brakes	Van's Aircraft	-	-	M. Cyl. MP-002	SRVFO2	1113	-	-	-	-	Included	-	-	-	-	-
RV8 - Grove LG finishing kit = main W + tires + axles	Van's Aircraft	5"	5.00-5	-	SRVFI03	1621	5"	11x4.00-5	SRV02A	369	-	-	-	-	BCH-002	24
RV10 finishing kit = main wheels + tires + axles	Van's Aircraft	6"	15x6.00-6	-	SRVFI05	2444	5"	5.00-5	SRVFI01	532	-	-	-	-	BCH-004	45

WHEELS & BRAKES - COMPLETE KITS

Aircraft Type	Manufacturer	Wheel Ø	Tires	Braking controls	Mains Kit P/N	Price	Nose/Tail Wheel Ø	Tire	Mains Kit P/N	Price	Copilot Brake P/N	Price	Parking valve P/N	Price	Main wheel Cap P/N	Unit Price
RV14 finishing kit = mains + tires + axles	Van's Aircraft	5"	5.00-5	-	SRVFI04	1681	5"	5.00-5	SRVFI01	532	-	-	-	-	BCH-002	24
RV14 fuselage kit = pilot/co-pilot brakes	Van's Aircraft	-	-	M. Cyl. MP-002	SRVFI05	1129	-	-	-	-	Included	256	PKG01	256	-	-
S19	Rans	5"	5.00-5	M. Cyl. MP-002	SRA03	1849	5"	5.00-5	SRA03A	532	COP01	409	PKG01	256	BCH-002	24
S6	Stemme	5"	5.00-5	Hand operated M. Cyl. HAB02	-	-	-	-	-	-	-	-	-	-	BCH-002	24
Savannah hand brake	ICP	6"	15x6.00-6	Hand operated M. Cyl. HAB02	SSV02	1557	6"	15x6.00-6	SSV01A	391	-	-	Included	-	BCH-002	24
Savannah pedal brakes	ICP	6"	15x6.00-6	M. Cyl. MP-002	SSV01	1767	6"	15x6.00-6	SSV01A	391	COP01	409	PKG01	256	BCH-002	24
SILA	AeroEast Eu.	6"	4.00-6	M. Cyl. MP-002	SIL01	1544	6"	4.00-6	SIL01A	391	-	-	PKG01	256	BCH-003	24
Sinus, Virus (tricycle)	Pipistrel	6"	4.00-6	M. Cyl. MP-002	SPP01	1958	4"	4.00-4	SPP01A	247	COP01	409	PKG01	256	BCH-003	24
Sinus, Virus (taildragger)	Pipistrel	6"	4.00-6	M. Cyl. MP-002	SPP01	1958	200x50	200x50	JC-01	163	-	-	-	-	-	-
Skylane	Airlony	6"	4.00-6	M. Cyl. MP-002	SSK02	1760	4"	4.00-4	SSK02A	247	COP01	409	PKG01	256	BCH-003	24
Skyleader 150/200	Skyleader	5"	11x4.00-5	Hand operated M. Cyl. HAB02	SSL01	1540	4"	4.00-4	SSL01A	247	COP04	303	Included	-	BCH-002	24
Skyranger	BestOff Air.	6"	4.00-6	Hand operated M. Cyl. HAB02	SSK01	1720	6"	13x5.00-6	SSK01A	391	COP04	303	Included	-	BCH-002	24
Speedcruiser	BOT	6"	4.00-6	M. Cyl. MP-002	SBT01	1616	4"	4.00-4	SBT01A	247	-	-	PKG01	256	BCH-003	24
SR20/22 single brake	Cirrus Air.	6"	15x6.00-6	Included in STC	STC-010	5399	5"	5.00-5	Included in STC	-	Included in STC	-	-	-	-	-
SR22/20 dual brake	Cirrus Air.	6"	15x6.00-6	Included in STC	STC-004	6490	5"	5.00-5	Included in STC	-	Included in STC	-	-	-	-	-
Sting Carbon	TL Ultralight	5"	11x4.00-5	Hand operated M. Cyl. HAB02	SSC01	1798	4"	4.00-4	SSC01A	247	COP04	303	Included	-	BCH-002	24
Storch	Fly Synthesis	6"	4.00-6	Hand operated M. Cyl. MP-004.6	SFS01	1639	4"	4.00-4	SFS01A	247	-	-	Included	-	BCH-003	24
Super Guépard	Aero S. Guépard	6"	13x5.00-6	Hand operated M. Cyl. HAB02	SGU01	1520	6"	15x6.00-6	SGU01A	391	COP04	303	Included	-	BCH-003	24
Super Stol Highlander	Just Aircraft	6"	-	M. Cyl. MP-003	SSJ01	2650	-	-	-	-	COP02	Incl.	PKG01	256	BCH-002	24
Tanarg	Air Création	-	-	1 regulator with brake lines	SAC01	256	-	-	-	-	-	-	-	-	-	-
Tetras	Humbert Aviation	6"	15x6.00-5	Hand operated M. Cyl. HAB02	STE01	1608	-	-	-	-	COP04	303	Included	-	BCH-002	24
Tetras for DATUM skis	Humbert Aviation	6"	4.00-6	Hand operated M. Cyl. HAB02	STE02	1908	-	-	-	-	COP04	303	Included	-	-	-
Topaz	Ekolot	6"	4.00-6	Hand operated M. Cyl. HAB02	SEK01	1660	4"	4.00-4	SEK01A	247	COP04	303	Included	-	BCH-003	24
Twin Otter DHC-6	Viking Air	-	-	-	-	-	8.90-12.5	-	STC-008	*	-	-	-	-	-	-
Vampire Century	Flying Machines	6"	4.00-6	Hand operated M. Cyl. HAB02	SVA01	1482	6"	4.00-6	SVA01A	391	COP04	303	Included	-	BCH-003	24
Vari'Ez	Rutan	5"	11x4.00-5	M. Cyl. MP-002	SLE02	1933	-	-	-	-	-	-	PKG01	256	BCH-002	24
Ventus2 A	Schempp Hirth	5"	11x4.00-5	Cable operated M. Cyl. HAC01	STC-007*	1019	-	-	-	-	-	-	-	-	-	-
VL3 Evolution	JMB Aircraft	6"	4.00-6	M. Cyl. MP-002	SVK01	1795	4"	4.00-4	SVK01A	247	COP01	409	PKG01	256	BCH-003	24
XL8 Bristol	BRM Aero	6"	4.00-6	Hand operated M. Cyl. HAB02	SBM01	1540	4"	4.00-4	SBM01A	247	-	-	Included	-	BCH-003	24
XL8 Bristol	BRM Aero	5"	5.00-5	M. Cyl. MP-002	SBM02	1820	4"	4.00-4	SBM01A	247	COP01	409	PKG01	256	BCH-002	24
Zenair CH601XL	Zenair	6"	15x6.00-6	M. Cyl. MP-002	SZH05	1788	6"	15x6.00-6	SZH05A	391	COP01	409	PKG01	256	BCH-002	24
Zephyr	Atec	6"	4.00-6	Hand operated M. Cyl. HAB02	SAZ01	1750	4"	4.00-4	SAZ01A	247	COP04	303	Included	-	BCH-003	24
Savage Tire <29"	Zlin Aviation	5"	-	M. Cyl. MP-002	SSA01	1849	4"	2.80/2.50-4	TW-001	1065	COP01	409	PKG01	256	BCH-002	24
Savage Tire >29" Dual brake caliper	Zlin Aviation	5"	-	M. Cyl. MP-002	SSA02	2140	4"	2.80/2.50-4	TW-001	1065	COP01	409	PKG01	256	BCH-002	24
Zodiac CH650	Zenair	6"	15x6.00-6	M. Cyl. MP-002	SZH06	1997	6"	15x6.00-6	SZH06A	391	COP01	409	PKG01	256	BCH-002	24
Zodiac CH750	Zenair	6"	15x6.00-6	M. Cyl. MP-003	SZH07	2036	6"	15x6.00-6	SZH07A	391	COP02	390	PKG01	256	BCH-002	24

PILATUS PC-6

Save up to 16€ / hour = Investment paid off in less than 1000 hours (maintenance cost = 3€ with BERINGER / 19€ with original parts)

180 Pilatus PC-6 equipped with the complete wheel & brake set, launched in 2010.

More than 240,000 landings/60,000h have proven the reliability and efficiency of the wheel & brake set.

Wheel dimension available: **12" and 10"**

**No corrosion
Optimised to last longer**



CIRRUS SR22/20

INCREASE YOUR SAFETY AND REDUCE YOUR ROLLING DISTANCE

SINGLE wheel & brake kit: lower operating costs

DUAL wheel & brake kit: more safety with dual caliper and the ALIR regulator

→ reduced landing distance for short runways

Both kits include the three tubeless wheels, pilot and co-pilot brakes, High Energy brakes with Formula1 ventilated pistons and cooling fins.



EXTRA 300

AMAZING PERFORMANCE and WEIGHT SAVING

The wheel and brake kit was developed in collaboration with Nicolas Ivanoff. BERINGER advanced technology has allowed to save 3.5kg (6.61 Lbs) due to the optimized design and to the manufacturing process. CNC machined parts are 2 to 3 times stronger than cast wheels.



DIAMOND DA42/DA42NG

DRAMATIC REDUCTION of WHEEL LOCKING and LIFE-CYCLE COSTS.
Investment paid off in less than 800 hours (estimated value, depending on the use).

Progressive rise in performance and better control of the brakes allow to reduce the stopping distance by 20% or more. It reduces the tire wear and increases the safety level. Discs and brake pads last 3x longer than standard. The complete upgrade includes the 6" main wheels, the 5" nose wheel and the brakes.

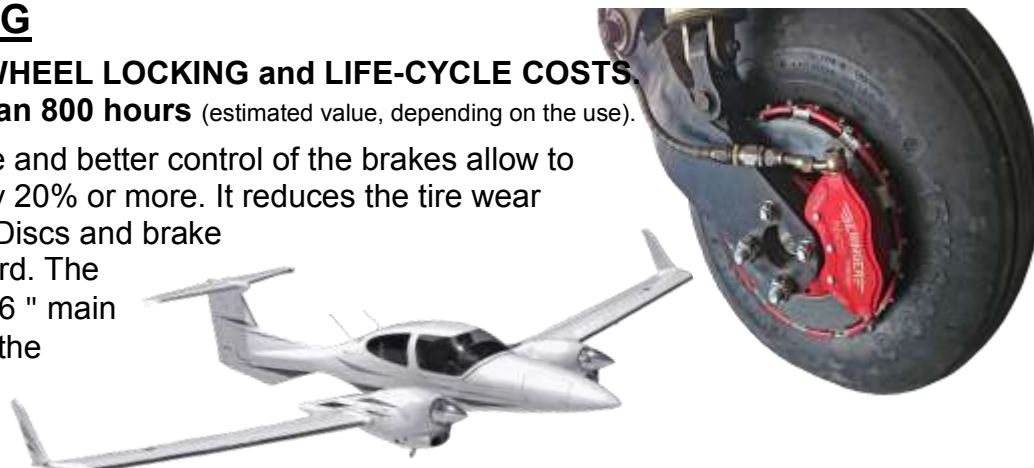

DIAMOND DA40NG TUNDRA

REDUCED STOPPING DISTANCE and MAINTENANCE COSTS - WEIGHT SAVING (5kg - 11 Lbs)

The TUNDRA kit for DA40NG allows to land safely on rough terrain. The complete upgrade includes the three tubeless wheels, the tires and the pilot/co-pilot brakes.

Stopping distances reduced
Weight saving – 5 kg/11 Lbs
Maintenance costs reduced



ROBIN DR400/DR300/HR2160

BRAKING SYSTEM UPGRADE: STRONG BRAKES

REDUCED STOPPING DISTANCE and MAINTENANCE COSTS

The kit includes 2 inner bowls to be bolt on the existing wheels that are supporting the floating brake discs, made in steel chrome molybdenum :

- ➔ No vibration at braking due to disc deformation
- ➔ The disc can expand when it heats up without any strength and avoid any buckling or crack



Twin Otter DHC-6:

SWITCH TO A HIGH PERFORMANCE NOSE WHEEL. OPTIMIZED TO LAST LONGER.

- Excellent resistance to corrosion due to the anodized aluminum parts.
- Greasing of the bearings spaced out due to lipseals, O-Rings.

More than 70 Twin Otter have been retrofitted so far



GLIDERS

UPGRADE YOUR BRAKES and SAVE WEIGHT (from 1.5 to 3.5kg)

Increase your safety when you land off-airfield. You can count on powerful brakes in any case.

The wheel is aluminum red anodized, fully CNC machined, with O-Ring for tubeless mounting. The brake caliper uses sintered metallic pads and stainless steel disc for increased life.

The kit includes a pressure limiter and the complete hydraulic line. The master cylinder can be cable operated.



TUBELESS



Extend the landing possibilities of your STOL airplane with **BERINGER** systems:

- Groundloop-resistant Tailwheel
- Alaskan Landing Gear for taildragger
- Ultralight Bush wheels
- Powerful dual brakes
- ALIR anti-skid
- Ultralight 26" Bush tires

We offer you a new dimension of freedom with bush wheels and low pressure tires.
Please refer to pages 11-14 for complete wheel and brake sets and page 25-26 for tires.



Dual braking system for tires over 29"
See page 14



Cross wind... are you ready? Patented groundloop-resistant tailwheel



Greater Safety for taildraggers



Double pivot system, lockable from the cockpit:

- **Unlocked:** the tailwheel is free to castor for taxiing. Steering is accomplished using the brakes on the rudder pedals.
- **Locked:** the tailwheel is locked to the rudder for take off and landing. The tailwheel follows the rudder movement.

For taildraggers up to 750kg (1500lbs) - robust design for rough airstrips.

Two types available:

Complete system including wheel and tire 2.80/2.50-4" (weight 3.77kg) = **1065€ P/N TW-001**

BUSH complete system including wheel and tire 4.00-4" (weight 4.12kg) = **1280€ P/N TW-002**

ALASKAN LANDING GEAR™

Rough terrain... Are you ready?



Greater Safety for taildraggers and backcountry pilots.

The ALG patented Landing Gear is designed to improve the safety on rough terrain. Thanks to the oleo-pneumatic shocks, it absorbs the surface defects.

The G-factor test has demonstrated that the ALG provides three times less structural impact

- High efficiency LG with oil/pneumatic, no-rebound dampers
- 12 inch damping travel - for high energy dissipation
- Strong design for bush use (3G proof tested)
- Lightweight, high strength aluminum (2024)

PATENTED

Combined with the BERINGER light and powerful wheels and brakes, as well as with the groundloop-resistant patented tailwheel, the ALG offers the **ULTIMATE LANDING SOLUTION** that protects the Aircraft airframe and improve the safety.

ALG landing gear for :	Price
Zlin Savage	4800
Just Aircraft Highlander	4800
Maverick	4800
Cubcrafters Carbon Cub	5335
PA18 SuperCub experimental	5335



The STC for the Piper SuperCub is in progress. Stay tuned...

WHEELS and BRAKES

4" - World's lightest in class ONLY 1.1kg (39 oz)

- Static load rating of 418 lbs (190kg)
- Size : 3.50-4
- Single-piston brake caliper
- Lightweight floating disc
- Suitable for light aircraft, up to 770 Lbs MTOW (350kg)

TUBELESS



5" - STANDARD SERIE

- Static load rating of 1,430 lbs (650kg)
- Sizes : 5.00-5 and 4.00-5
- 2 piston standard brake
- Lightweight stainless steel disc
- Suitable for LSA and gliders

PATENTED

TUBELESS



RF-002
+ EA-006

5" - HE SERIES

TSO & ETSO

- Static load rating of 1,430 lbs (650kg)
- Sizes : 5.00-5 and 4.00-5
- HE caliper 2 piston with cooling fins
- + 40% braking torque
- 2 types of high strength discs
- Insulated full metallic brake pad
- Caliper EA-002: for 2 seat aircraft (RV's)
- Caliper EA-002.2 (thicker disc): for high landing speed aircraft (Lancair, Glasair, Aerobatic...)

PATENTED

TUBELESS



RF-005
+ EA-002

(HE means High Energy)

6" - SL

The SL wheel designed in 2 parts instead of 3, is even lighter and allows an easy maintenance.

Static load rating is increased up to 935 lbs (425kg) to fit Aircraft up to 1,870 Lbs (850kg) (gross weight)

- Easy maintenance: only 1 o-ring seal
- Sizes : 4.00-6 and 6.00-6
- 2 piston standard brake and lightweight stainless steel disc
- Suitable for ultra light aircraft and LSA

PATENTED

The RF-009 with dual caliper EA-006 is available for tires >29" (increased braking torque).

The RF-014 6.00-6 SL wheel includes a larger bearing in the inner rim (brake side).



RF-004
+ EA-006



RF-009
+ 2xEA-006

WHEELS and BRAKES

6" - LE

Designed for SuperCub and similar airplanes.

- Static load rating 1,364 lbs (620kg) to fit Aircraft up to 2,728 Lbs (1240 kg) (gross weight)
- Easy maintenance: only 1 o'ring seal
- Size : 6.00-6"
- 2 piston brake EA-003.2 **PATENTED**
- stainless steel disc
- Suitable for SuperCub and similar airplanes.

NEW

RF-015
+ EA-003.2



6" HE SERIES

TSO & ETSO

(HE means High Energy)

- Static load rating 2,090 lbs (950kg)
- Size : 6.00-6"
- HE caliper 2 piston with cooling fins **PATENTED**
- doubled braking torque compared to SL series
- 2 types of high strength discs
- Insulated full metallic brake pads
- Caliper EA-003: for 2 seat aircraft (Taildragger, Champion, Glasair)
- Caliper EA-003.3 (thicker disc): for 4 seat aircraft (Lancair IV, Cirrus SR20)
- Caliper EA-003.4: dual caliper for increased braking torque, ultra short braking distance (suitable for Cirrus SR22, DA42,...)

TUBELESS



RF-006
+EA-003

8" (RF-010)

- Static load rating 2,750 lbs (1250kg)
- Size : 18x5.5
- HE caliper EA-008, 2 piston with cooling fins
- High strength discs
- Insulated full metallic brake pads



RF-010
+EA-008

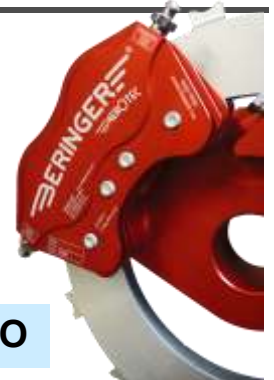

TSO & ETSO

10" (RF-011) and 12" (RF-003)

- Static load rating 3,080lbs (1400kg)
- Sizes: 10" : 24x7.7 and 12" : 11.00-12"
- Caliper EA-001, 3 piston
- Insulated full metallic brake pads



RF-011
+EA-001



WHEEL CAPS

- Anodized cap for wheel - Billet aluminum machined on CNC
- Available for 5" - 6" wheels



WHEELS and BRAKES

Assy P/N	Certification	Wheel size	Static load kg	Limit load kg	Caliper P/N	Disc P/N	Braking torque inch.-lbs	Max RTO Energy ft.-lbs	Weight Lbs	Price Per assy
4" WHEELS										
RF-013	-	3.50-4"	189.60	663.61	EA-009	DSC-013	1400	105000	1.10	308
5" WHEELS - STANDARD series										
RF-002	-	5.00-5"	649.54	2599.54	EA-006	DSC-006	2450	140000	1.97	380
RF-007	-	4.00-5"	649.54	2599.54	EA-006	DSC-006	2450	140000	1.88	380
5" WHEELS - HE series										
RF-005	TSO	5.00-5"	649.54	2599.54	EA-002	DSC-008	3500	210000	2.448	452
RF-005	TSO	5.00-5"	649.54	2599.54	EA-002.2	DSC-008.2	3500	361000	2.68	493
RF-012	-	4.00-5"	649.54	2599.54	EA-002	DSC-008	3500	210000	2.31	452
RF-007	-	4.00-5"	649.54	2599.54	EA-002.2	DSC-008.2	3500	361000	2.59	493
6" WHEELS - SL										
RF-009	-	6.00-6	424.11	1496.85	EA-006	DSC-006	2450	140000	2.08	450
RF-004	-	4.00-6	424.11	1496.85	EA-006	DSC-006	2450	140000	1.94	409
6" WHEELS - LE										
RF-015	-	6.00-6	618.70	2165.45	EA-003.2	DSC-014	4900	250000	2.95	512
6" WHEELS - HE series										
RF-006	TSO	6.00-6	943.47	3392.87	EA-003.5	DSC-009.4	9800	550000	5.26	918
RF-006	TSO	6.00-6"	943.47	3392.87	EA-003	DSC-009	4900	355000	3.76	576
RF-006	TSO	6.00-6"	943.47	3392.87	EA-003.3	DSC-009.3	4900	500000	4.13	617
RF-006	TSO	6.00-6"	943.47	3392.87	EA-003.4	DSC-009.3	9800	550000	4.9	751
8" WHEELS										
RF-010	TSO	18x5.5	1247.38	4365.83	EA-008	DSC-012	8300	1115000	7.58	*
10" WHEELS										
RF-011	-	24x7.7	1397.06	3702.22	EA-001	DSC-011	16900	845000	11.38	*
12" WHEELS										
RF-003	-	11.00-12"	1397.06	3702.22	EA-001	DSC-011	16900	845000	14.07	*

CAUTION: static load valid only with appropriate tire
For wheel and brake spare parts, see table pages 40-41.

1 lbs ↔ 0.45 kg 1 kg ↔ 2.2 lbs

* contact us

4.00-5" Wheel



5.00-5" Wheel

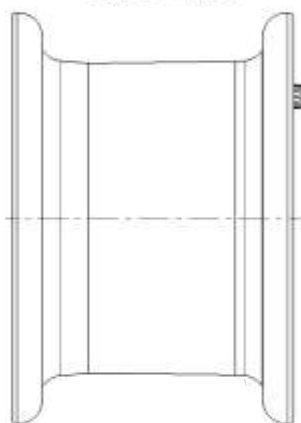

Cap P/N	main wheel	Unit Price
BCH-003	4.00-6" SL series	24
BCH-002	5" and 6.00-6" SL series	24
BCH-004	6" HE series	45
BCH-005	8"	45
BCH-001	10" and 12"	113

FINISH : Red anodizing is standard color for wheels, brakes and master cylinders.
Calipers are ALWAYS red. Other colors can be available for certain wheels on special order with an extra delay at an additional cost of **85€** per batch of parts. *WARNING: Colors may vary.*

VINTAGE SPOKE WHEEL WITH BRAKE

- Tire 3.50-19" Ribbed (vintage style)
- Aluminum rim with stainless steel spokes
- Load: suitable for Aircraft < 1,100lbs
- Price: **802€** per wheel (including wheel+brake+tire+tube+spokes)
- Weight: 20lbs (wheel+brake+tire+tube+spokes)



NOSE WHEELS and TAILWHEELS

Beringer WHEELS without brake for nose wheel or tail wheel are:

- High strength aluminum alloy machined from solid on CNC
- TUBELESS (except JC-01) two or three pieces plus O-Ring and rigid valve
- Sealed ball bearings for optimal durability
- Use BERINGER tapered axles with those wheels (except 200x50 version)

TAIL WHEEL 200x50 RA-004

- Tire 200x50 with tube
- For 5/16" bolt
- Weight : 260g
- Only fork mounting
- Suitable for Pipistrel Sinus

**Delivered mounted with
6ply tyre and tube**

830g
TUBE TYPE



4" ultralight WHEEL

- Bush tail wheel
- Nose wheel for LSA ULM
- High load rating
- Cantilever **OR** fork mounting
- Perfect for ultralight aircraft

TUBELESS



540g
TUBELESS



5 " NOSE WHEEL

for homebuilt aircraft

TUBELESS



6" SL NOSE WHEEL

for ultralight aircraft and LSA

TUBELESS



Part/N	certification	size	Weight lbs (kg)	Static load lbs (kg)	Limit load lbs (kg)	Price
RA-004		200x50	1.83 (0.830)	300 (137)	1050 (477)	163
RA-003		3.50-4"	1.20 (0.545)	418 (190)	1463 (665)	174
RA-007		13.5X6.0-4"	2.86 (1.300)	1430 (650)	5000 (2275)	*
RA-002	TSO	5.00-5"	2.68 (1.220)	1430 (650)	5731 (2605)	334
RA-011		4.00-5"	2.46 (1.120)	1430 (650)	5731 (2605)	255
RA-009		4.00-6 SL	2.63 (1.195)	935 (425)	3300 (1500)	290
RA-010		6.00-6 SL	2.96 (1.345)	935 (425)	3300 (1500)	321
RA-005	TSO	6.00-6 HE	4.53 (2.059)	2090 (950)	7480 (3400)	411
RA-008	TSO	8.90-12.5"	16.39 (7.450)	1980 (900)	8910 (4050)	4148

AXLES

Material: High strength anodized aluminum or high strength steel with nickel coating

- Different types of axle available:
 - for wheel fork (supported at both ends)
 - for cantilever installation
- FEM calculated for optimized weight and stress distribution and optimized weight

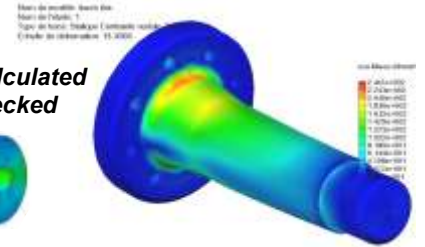

AXLE BOLT TEMPLATES (dimensions in inches)

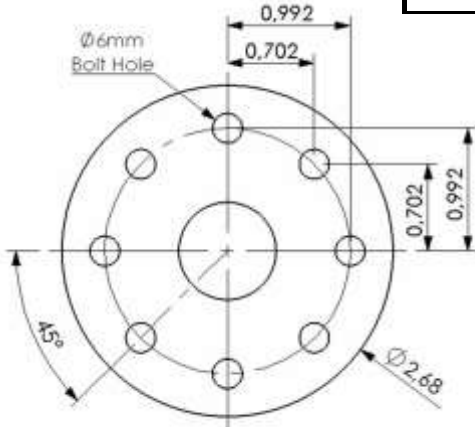

T1

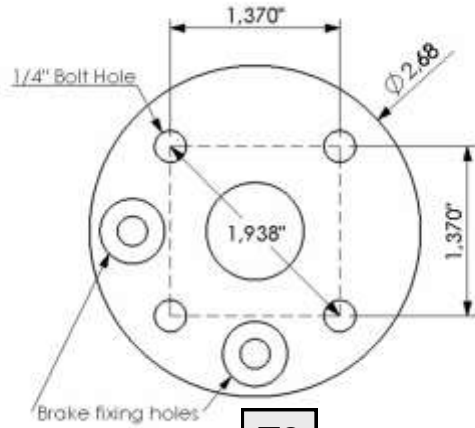

T2

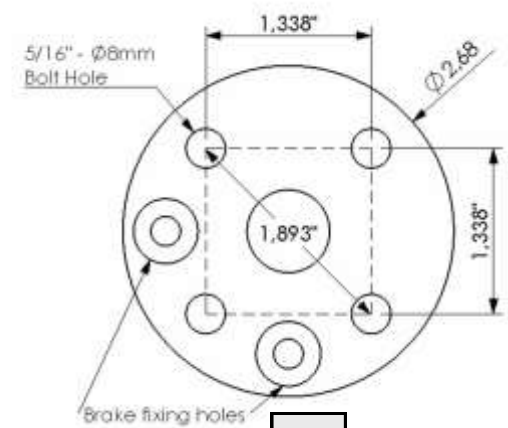

T4

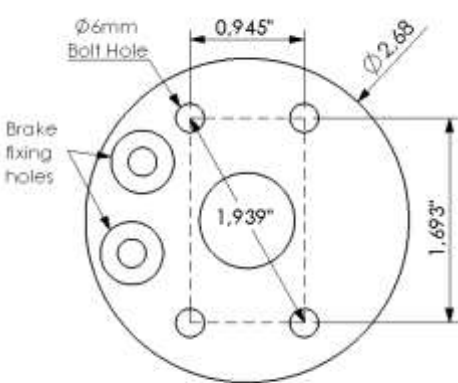

T5

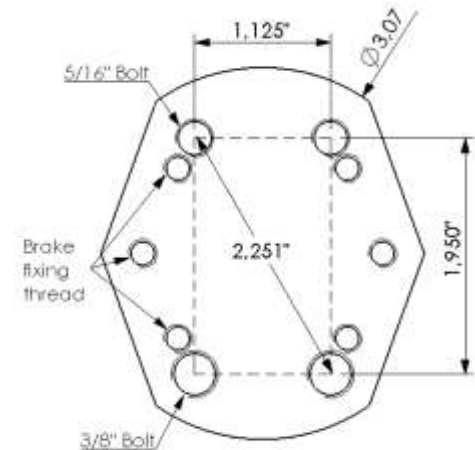

T3

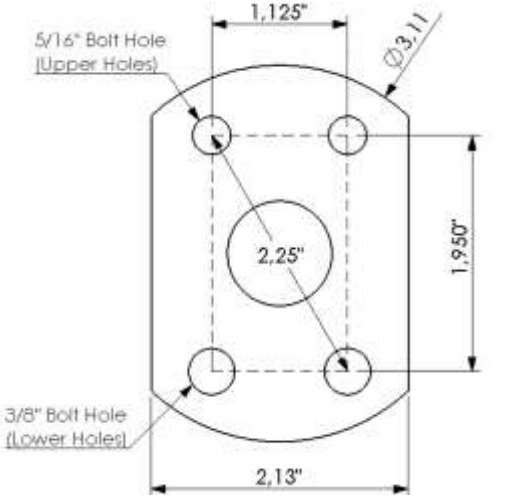

T3

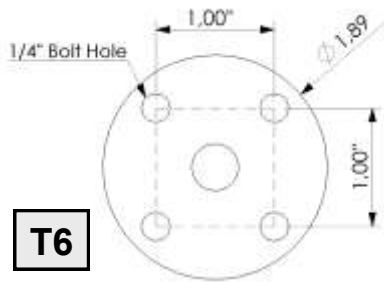

T6

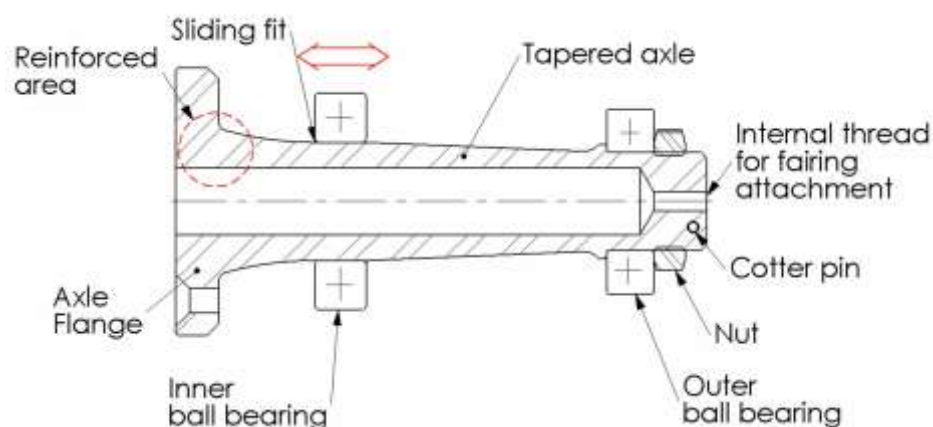

AXLES



1 lbs ↔ 0.45 kg
1 kg ↔ 2.2 lbs

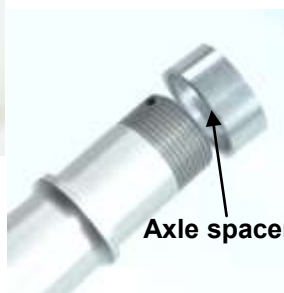

Part n°	DESCRIPTION (all aluminum axles are anodized)	Axle thread	Static load rating per axle kg	Limit load kg	Weight g	Unit price
FUS-001 T1/T2/T4/T5	Tapered aluminum Axle	M25x1.5	340	1182	240	66
FUS-004 T2	Tapered steel Axle <i>Nickel coated</i>	M25x1.5	650	2300	620	142
FUS-005 T1/T2/T4/T5	Tapered aluminum Axle	M25x1.5	430	1545	210	66
FUS-006 T6	Tapered aluminum Axle	M15x1	182	636	40	61
FUS-007 T3	Tapered aluminum Axle	M35x1.5	750	2625	506	142
FUS-008 T3	Tapered aluminum Axle	M25x1.5	320	1050	400	122
FUS-009 T2	Tapered aluminum Axle	M25x1.5	390	1365	240	101
FUS-010 T1/T2/T4/T5	Tapered aluminum Axle	M25x1.5	370	1295	332	101
FUS-011 T3	Tapered Aluminum Axle <i>Rans pattern</i>	M25x1.5	355	1241	286	66
FUS-013 T1	Tapered aluminum Axle <i>Datum ski use</i>	M25x1.5	355	1241	360	134
FUS-014	Tapered Aluminum Axle	M30x1.5	546	1909	404	142
ECR-002	Aluminum nut M25x1,5	M25x1.5	-	-	5	10
ECR-004	Aluminum nut M30x1,5	M30x1.5	-	-	7	20
ECR-001	Aluminum nut M35x1,5	M35x1.5	-	-	10	20
ZSC01	Steel nut M15x1	M15x1	-	-	10	6
BGE-016	Spacer for axle FUS-001		-	-	20	9

Wheel size→ Axle P/N ↓	3.50-4"	4.00-5" & 4.00-5"HE	5.00-5" & 5.00-5"HE	4.00-6" SL	6.00-6" SL	6.00-6" LE	6.00-6" HE
FUS-001	-	-	T1, T2, T4, T5	T1, T2, T4, T5	-	-	-
FUS-004	-	-	T2	-	-	-	-
FUS-005	-	T1, T2, T4, T5	-	-	-	-	-
FUS-006	T6	-	-	-	-	-	-
FUS-007	-	-	-	-	-	-	T3
FUS-008	-	-	-	-	T3	-	-
FUS-009	-	-	T2	-	-	-	-
FUS-010	-	-	-	-	T1, T2, T4, T5	-	-
FUS-011	-	-	-	T3	-	-	-
FUS-013	-	-	-	T1	-	-	-
FUS-014	-	-	-	-	-	T3	-

Alaskan Bush Tire

THE FIRST FULL-UP BUSHWHEEL
BUILT SPECIFICALLY
FOR LSA AND ULTRALIGHT AIRCRAFT
Smooth landing, even on rough terrain.

PRODUCED in Alaska for BERINGER
By Airframes Alaska, Expert in Alaskan bush tires.



- Low pressure tire
- For 6.00-6 inch wheels
- Diameter: 26" (65 cm)
- Weight: 6.9kg (15.21 lbs)
- Unit Price: 995€

NEW

Features: Kevlar cording - reengineered sidewalls that provide the ideal flex and energy absorption for lighter aircraft.

This tire is BERINGER AERO exclusivity for Europe

TIRES

P/N	Description	Static load lbs	Ø A (inch)	B (inch)	Weight kg	Price
PAG05	200X50 tire and tube 6ply - TT	-	7.90	2	0.50	45
PAG07	2.80/2.50-4 6PLY - Kenda - TL	-	9.00	2.75	0.58	24
PAG04	2.80/2.50-4" 6PLY - Aeroclassic -TT	475	9.00	2.75	0.76	55
PAG02	3.00-4" 4 PLY - Veloce - TL	-	10.35	3.54	0.60	24
PAG06	10x3.50-4" 4 PLY - Aero classic - TT	460	9.84	3.23	1.15	58
PAG01	4.00-4" 4 PLY - Kenda - TL	-	11.90	3.93	1.00	24
PAG03	4.00-4" 8 PLY - Aeroclassic - TL	800	12.00	4.3 0	1.30	65
PAC01	11x4.00-5" 8 PLY - Aero Classic - TL	650	11.60	3.78	1.70	55
PAA02	5.00-5" 10 PLY - Michelin AVIATOR - TL	2150	14.20	4.65	2.60	149
PAB01	380x150/15x6.00-5 6PLY -Michelin AIR - TT	1598	14.96	5.50	3.00	179
PAD01	4.00-6" 6 PLY SAVA - TT	-	14.50	4.40	1.30	42
PAD03	4.00-6" 6 PLY - AeroClassic - TL	-	14.50	4.40	1.68	65
PAC03	13x5.00-6" 4 PLY - Deli - TT	-	13.40	4.65	1.30	39
PAC07	13x5.00-6 4PLY - Sava - TL	-	13.40	4.65	1.50	39
PAC04	13x5.00-6" 8 PLY -Sava - TL	-	13.40	4.65	1.50	39
PAC02	15x6.00-6" 6 PLY - Sava - TL	-	14.75	5.10	2.20	39
PAC05	15x6.00-6" 6 PLY - Air Trac - TT	1950	15.00	5.30	2.80	119
PAC06	15x6.00-6 6PLY - Aeroclassic - TL	1950	15.00	5.30	3.54	149
PAB03	6.00-6" 4 PLY -Air Trac - TT	1150	17.50	6.30	3.06	115
021-317-1	6.00-6 8PLY - Michelin- TL	2350	17.50	6.30	4.36	189
021-327-1	17.5x6.25-6 8 PLY - Michelin -TL	2900	17.50	6.30		289
PAE01	8.00-6" 4ply - Carlisle - TT	-	17.70	7.10	3.90	109
PAF03	21x8.00-6" 4 PLY - Aeroclassic TUNDRA - TL	800	20.50	7.10	4.90	119
076-325-0	8.50x6 6PLY - Michelin - TL	2275	21.00	7.50	7.00	289
PAF05	22x8.50-6" 4PLY - Aeroclassic - TT	1600	22.00	8.10	4.00	225
PAF06	26x12x6 4 ply - ABT (Alaskan Bush Tire) - TL	-	26.38	10.04	6.50	995

Wheel size → ↓ Tire size	200x50	3.50-4	4.00-5	5.00-5	4.00-6	6.00-6"
200x50	ok	-	-	-	-	-
2.80/2.50-4"	-	ok	-	-	-	-
3.00-4"	-	ok	-	-	-	-
10x3.50-4"	-	ok	-	-	-	-
4.00-4"	-	ok	-	-	-	-
11x4.00-5"	-	-	ok	-	-	-
5.00-5"	-	-	*	ok	-	-
380x150-5" (15x6.00-5)	-	-	-	ok	-	-
13x5.00-6"	-	-	-	-	ok	-
4.00-6"	-	-	-	-	ok	-
15x6.00-6"	-	-	-	-	ok	ok
6.00-6" - 17.5x6.25-6	-	-	-	-	ok	ok
8.00-6"	-	-	-	-	-	ok
21x8.00-6"	-	-	-	-	-	ok
8.50-6"	-	-	-	-	-	ok
22x8.50-6"	-	-	-	-	-	ok
26" 29" 31" Bushwheel	-	-	-	-	-	ok

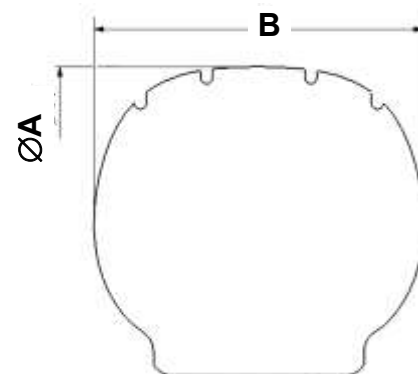

4.00-5"
 B C
15x6.00-6"
 A B C
A : Outside diameter of tyre (inches)
B : Tyre width (inches)
C : Inside diameter of tyre (inches)

1 lbs ↔ 0.45 kg 1 inch ↔ 25.4mm
1 kg ↔ 2.2 lbs

Notes: the dimensions and the weight of the tires may vary. BERINGER AERO cannot be responsible for the load indicated, which are those given by the tire manufacturers.

BERINGER wheels are tubeless. WE RECOMMEND FIRST MOUNTING OF TIRES ON WHEELS IN OUR PLANT. This service, free of charge, includes a pressure test, ensuring maximum security of the assembly.

MASTER CYLINDERS

These master cylinders have been designed for a very long life and assure very long trouble free service. We have tested them over 200,000 cycles with success. The piston is protected from dust by a lipseal.

- Available for DOT4 fluid **OR** for MINERAL (MIL FLUID) (seals are different, never mix)
- High quality aluminum alloy machined from solid on CNC
- 100% protected from corrosion: anodized coating and stainless steel components
- Light weight: more than 30% of weight saving compare to standard master cylinder
- Ultralow friction for improved efficiency



MP-001 series - BORE 9/16"

Attachments available

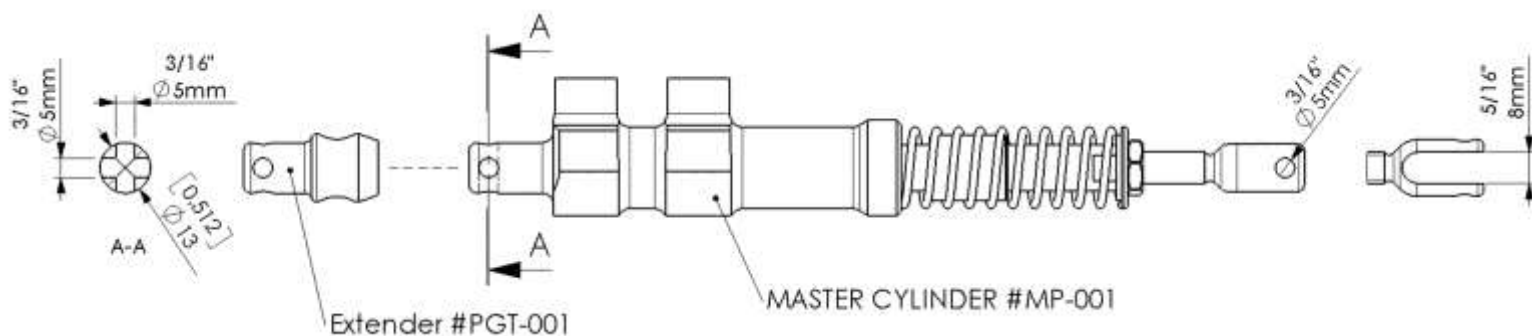

Pin-to-Pin length

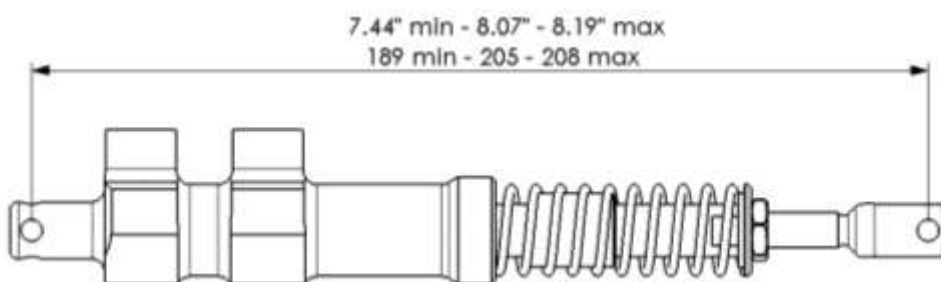
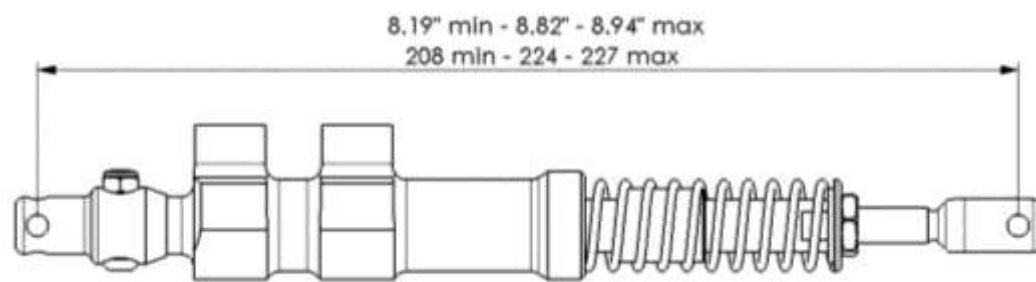

MASTER CYLINDERS

MP-002 series - BORE 1/2"



Attachments available

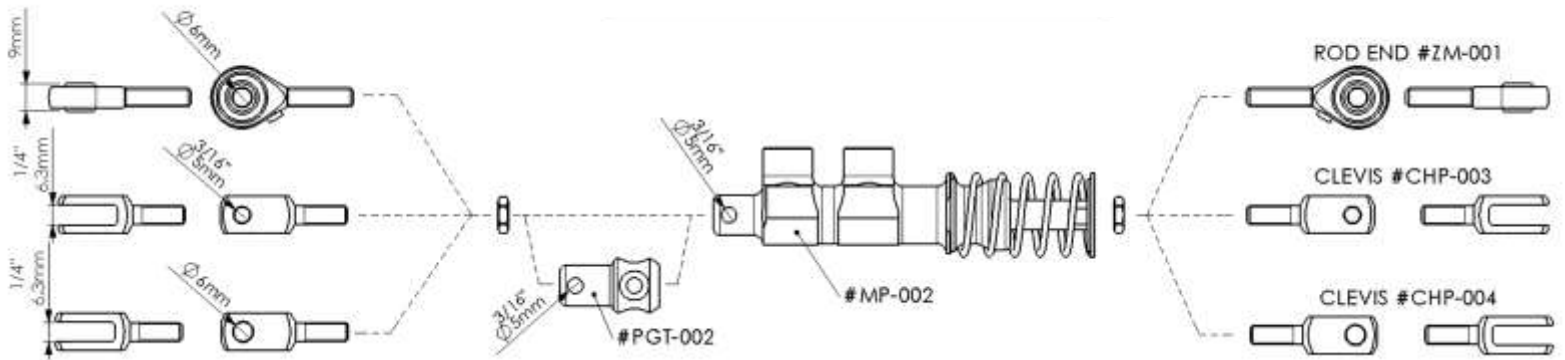

MP-002 : Pin-to-Pin length

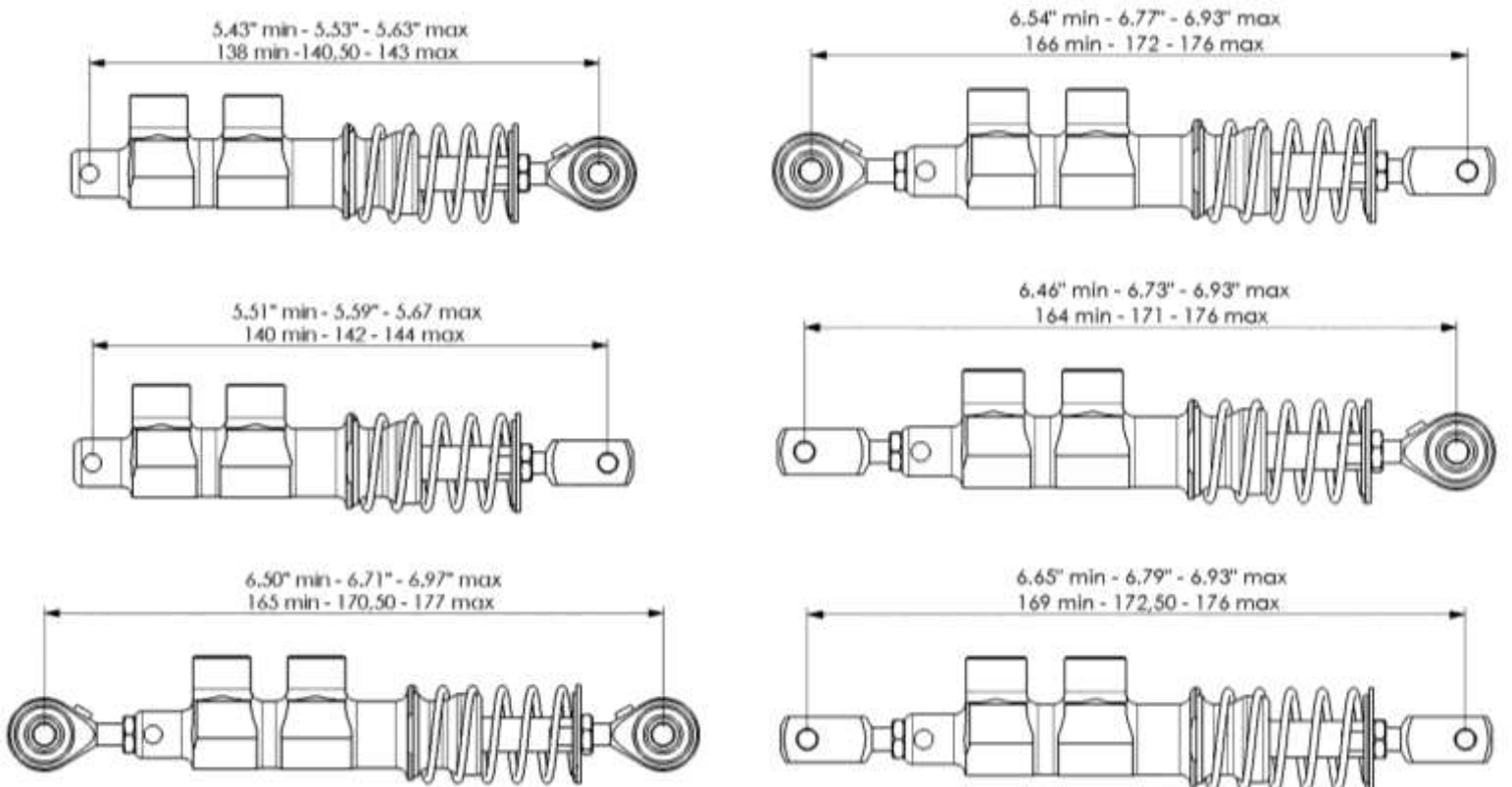

MASTER CYLINDERS

MP-003 series - BORE 1/2"



Attachments available

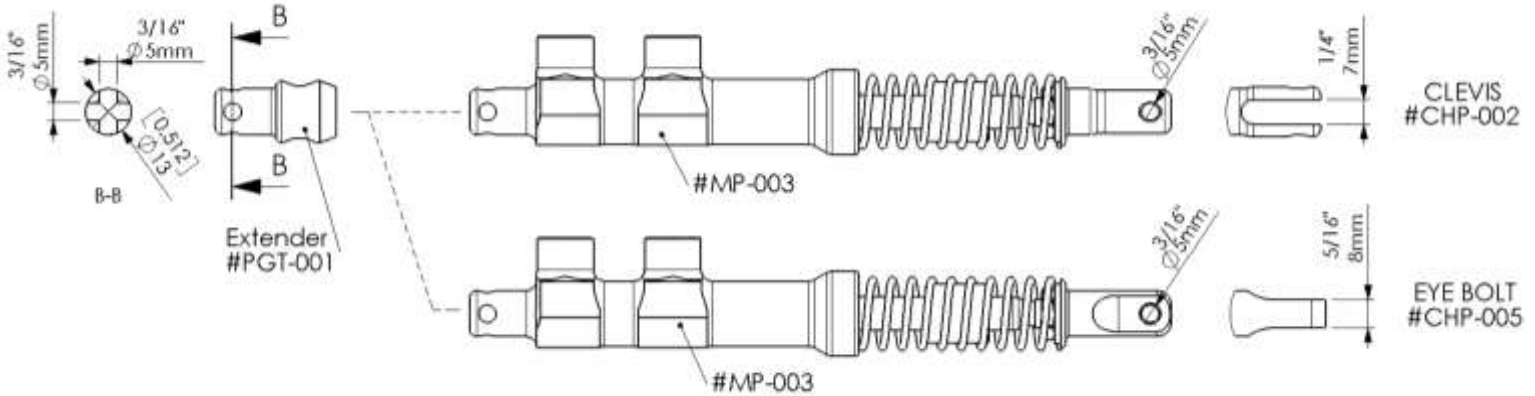

Pin-to-Pin length

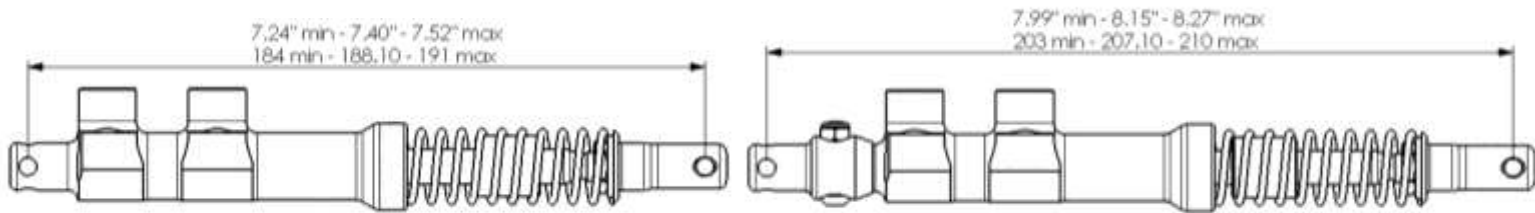

MASTER CYLINDERS extenders and adapters

Extenders can bring all master cylinders to a longer pin-to-pin distance.

- for MP-001 and MP-003 use PGT-001
- for MP-002 use PGT-002

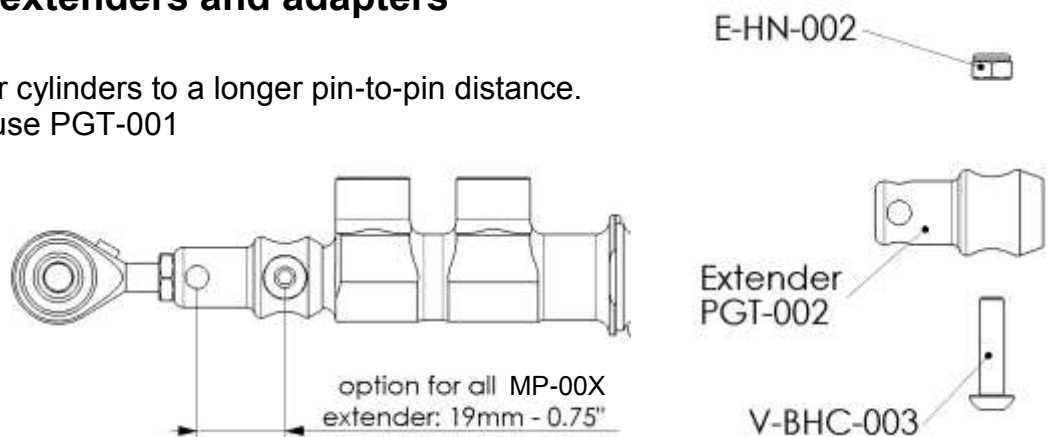

Adapter for rod ends:

our rod ends are only metric $\text{\O}6\text{mm}$. For connexion with 3/16" bolts, please order the adapter P/N: BGE-011

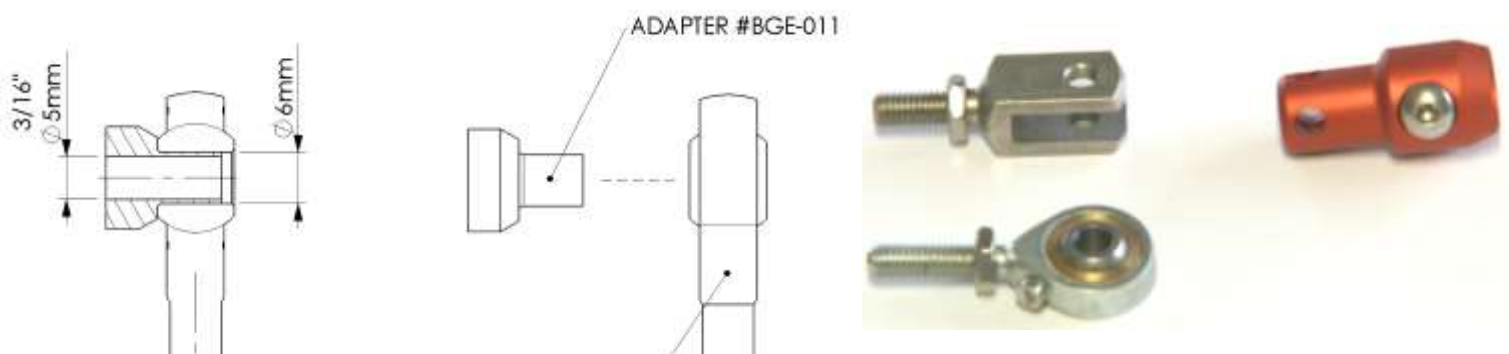

LEVER MASTER CYLINDERS

HAND OPERATED

SINGLE
MP-004.3
+MP-002
+CHP-003

DUAL
MP-004.4
+2XMP-002
+2XCHP-003



NEW

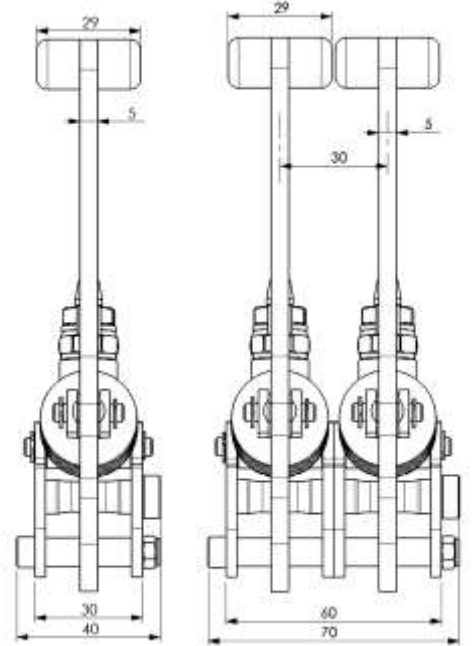

CABLE OPERATED

SINGLE
MP-004.1
+MP-002
+CHP-003



DUAL
MP-004.2
+2XMP-002
+2XCHP-003

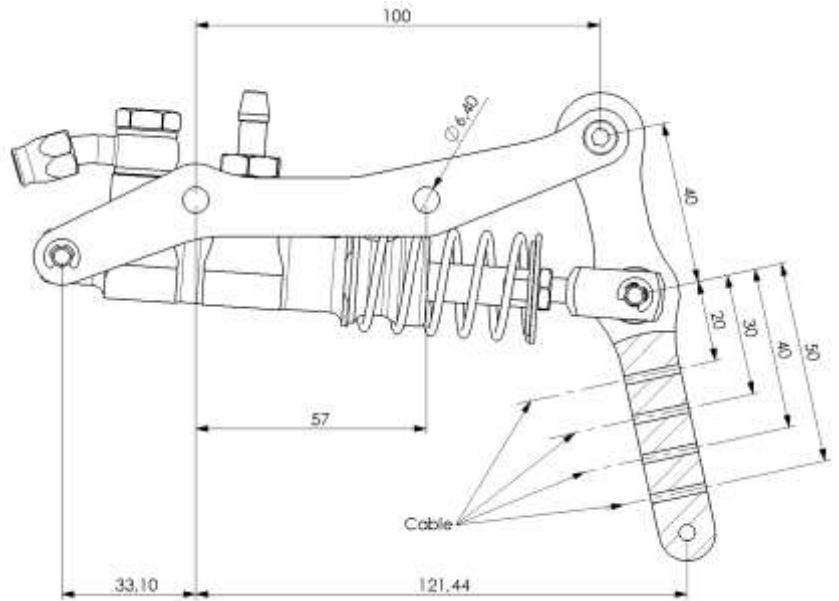
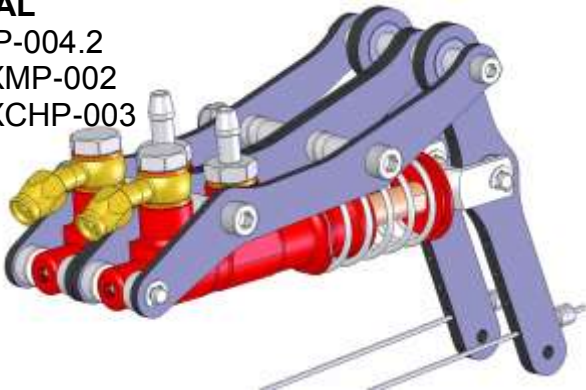

KITS for MP-002

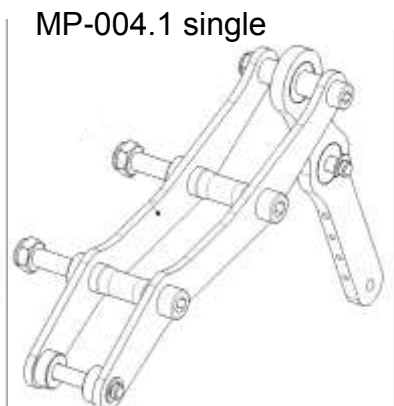
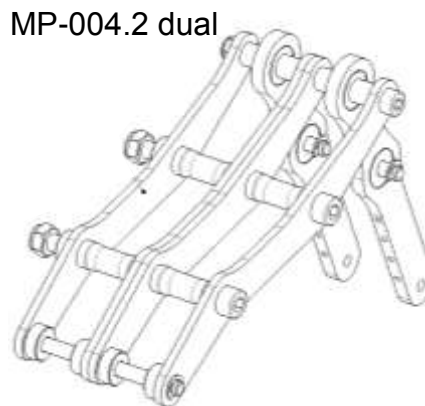
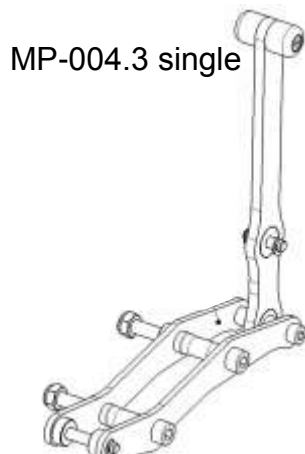
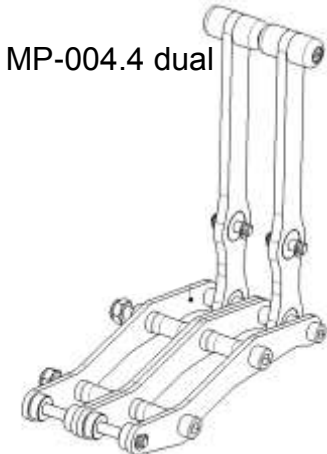

MASTER CYLINDERS - ATTACHMENTS

CAUTION:

MP-002E or MP-002N



The seals inside the MASTER BRAKE CYLINDERS are specific for each type of brake fluid.

- It is not possible to put DOT4 brake fluid in a master cylinder with seals for MINERAL (MIL) fluid and it is not possible to put MINERAL brake fluid in a master cylinder with seals for DOT4 brake fluid.

- The letter **E** means for DOT4 brake fluid
- The letter **N** means for MINERAL (MIL) brake fluid

P/N	Description	Brake fluid	Note	Piston bore inch	Standard pressure PSI	Max pressure PSI	Weight g	Unit Price
MP-001N	Master cylinder	Mineral		9/16	870	870	159	180
MP-002E	Master cylinder	DOT4	*	1/2	870	1450	94	143
MP-002N	Master cylinder	Mineral	*	1/2	870	1450	94	143
MP-003E	Master cylinder	DOT4	*	1/2	870	1450	113	149
MP-003N	Master cylinder	Mineral	*	1/2	870	1450	113	149
MP-004.1	Single Lever kit - cable operated		**	-	-	-	159	50
MP-004.2	Dual lever kit - cable operated		**	-	-	-	318	97
MP-004.3	Single lever kit - hand operated		***	-	-	-	139	61
MP-004.4	Dual lever kit - hand operated		***	-	-	-	272	112
MP-004.5	Single bent lever kit - hand operated		**	-	-	-	136	61
MP-004.6	Single lever kit - hand operated wi/ parking brake		**	-	-	-	170	112
PGT-001	Extender with bolt for MP-001 and MP-003			-	-	-	0	14
PGT-002	Extender with bolt for MP-002			-	-	-	9	14
PGT-003	Extender with bolt for MP-002			-	-	-	10	14
ZM-001	Rod end			-	-	-	23	14
CHP-002	Clevis for MP-003			-	-	-	7	12
CHP-003	Clevis for MP-002			-	-	-	14	12
CHP-004	Clevis for MP-002			-	-	-	14	12
CHP-005	Eye bolt for MP-003			-	-	-	9	12
BGE-011	Adapter for rod end			-	-	-	4	4

* For MP-002 and MP-003 the ends must be ordered separately

1 bar ↔ 14.5 psi - 1 psi ↔ 0.069 bar

** Master cylinder is not included in the kit. Please order one MP-002 (E or N) and one CHP-003

*** Master cylinders are not included in the kit. Please order two MP-002 (E or N) and two CHP-003

Hydraulic fittings for MASTER CYLINDERS (see pages 38-39)

Only few examples of hydraulic fittings and adaptors are shown. Many other combinations are available.

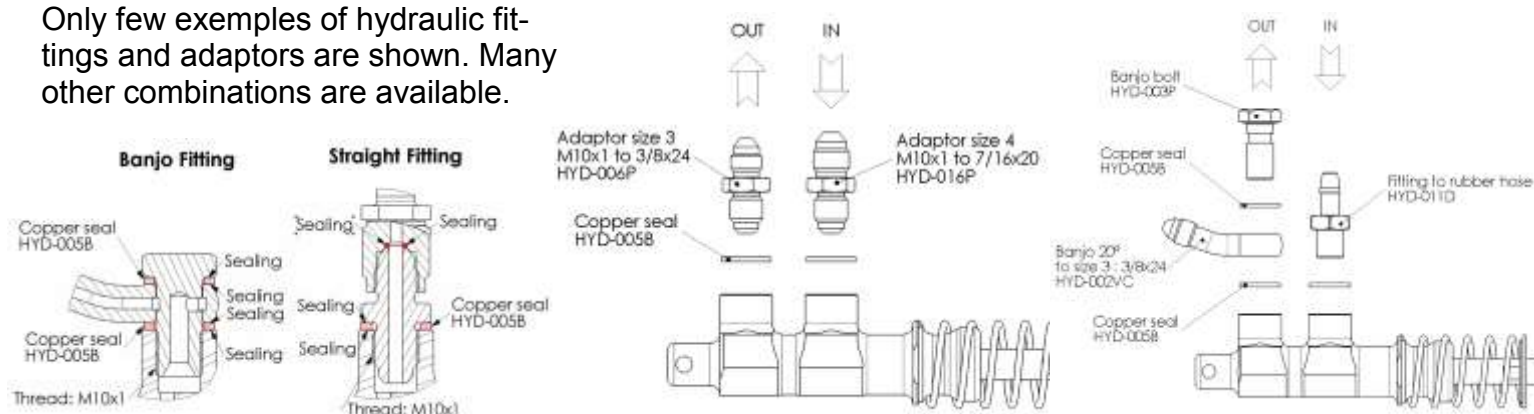

BRAKE FLUID RESERVOIRS

Each master cylinder requires a reservoir. We propose several types depending on your plane configuration. The reservoirs always incorporate tight bellows and are 100% tight, without any risk of leak. You must not install them close to the engine (install only inside the cockpit).

INTEGRAL BRAKE FLUID RESERVOIR

Vertical or horizontal mounting - available for DOT4 **OR** MINERAL brake fluid

- CNC machined from aluminium billet
- Weight : from 55g (2 oz) to
- Attaches directly to the master cylinder, 180° rotatable
- Perfect for aerobatic use

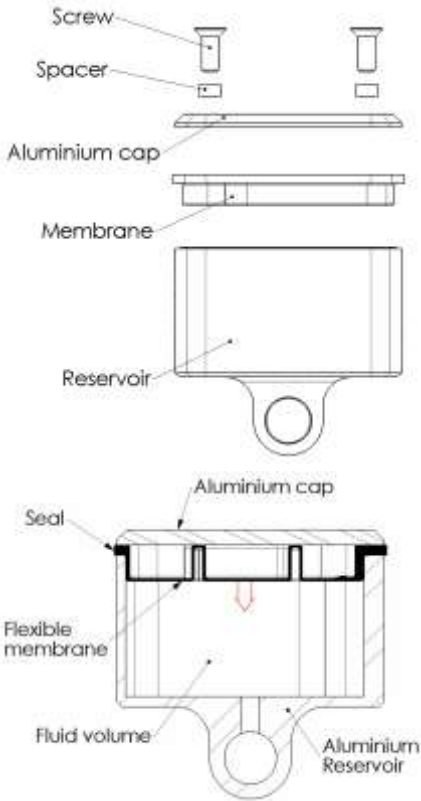

REMOTE BRAKE FLUID RESERVOIR

Transparent reservoir with CNC aluminium cover and visible fluid level and with mounting kit and 0.50m of EPDM tube. **Available for DOT4 brake fluid only.**

It is not possible to put DOT4 brake fluid in a master cylinder with seals for MINERAL (MIL) fluid and it is not possible to put MINERAL brake fluid in a master cylinder with seals for DOT4 brake fluid.

- The letter **E** means for DOT4 brake fluid
- The letter **N** means for MIL brake fluid



P/N	Brake fluid type	DESCRIPTION	weight g	Price
HFA01	E	Remote reservoir kit	39	33
RV-001	E or N	Integral reservoir CNC machined	55	49
RV-003	E or N	Integral reservoir CNC machined (Van's for example)	45	49
RV-004	E or N	Integral reservoir CNC machined - threaded port	36	49
RV-004.1	E or N	Integral reservoir CNC machined - unthreaded port	36	49

MASTER CYLINDERS FOR CONTROL STICK

HAND MASTER CYLINDER AEROTEC®

- Built-in reservoir
- Parking brake pin optional
- Three ball bearings for smooth operation, long life
- Covered with the world-wide AEROTEC® patents, it brings exceptional brake feeling
- Machined from billet on CNC
- To install on 22mm (7/8") or 25mm (1") axle or directly on flat surface with 2 screws

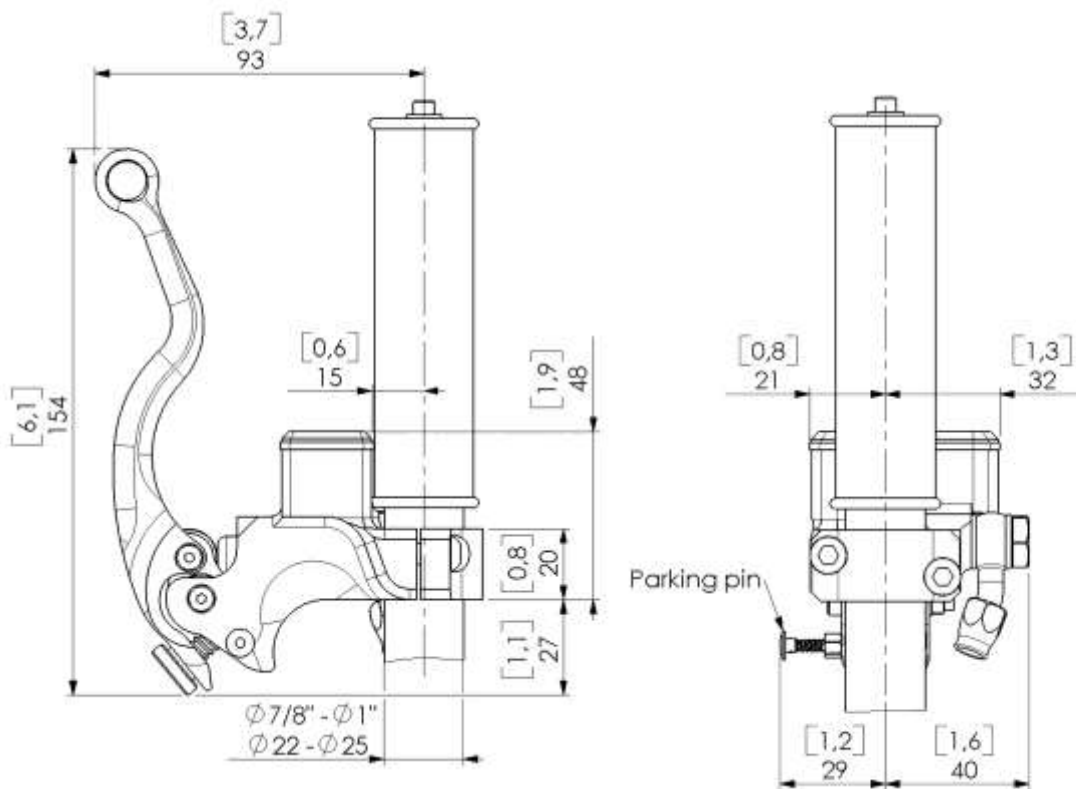

MASTER CYLINDER - CABLE OPERATED

- Built-in reservoir, delivered with aluminum support
- Actuated with sleeved cable
- only available for DOT4



MASTER CYLINDER - HAND OPERATED

All in one: lever, master cylinder, sealed reservoir. To be mounted on Ø22mm (0.866") axle or on support with two 6mm screws.

P/N	DESCRIPTION	Weight g	Brake fluid	Price
HAB01	Built-in master cylinder	295	DOT4	244
HAB02	Built-in master cylinder with mechanical parking brake pin	295	DOT4	262
HAA03	Additional master cylinder to mount in serie (double braking control). To be used with primary HAB01 or HAB02	284	DOT4	262
HAC01	Master cylinder CABLE actuated with support	295	DOT4	244
HAB04	Master cylinder with built-in reservoir	295	DOT4	262



ULTRA LIGHT PRESSURE LIMITER

PRESSURE LIMITER

Ultralightweight PRESSURE LIMITER for symmetrical braking on two wheels or one wheel system

- Limits progressively the pressure in the braking system from 25, 35, 45 or 60bars
- Highly recommended to avoid over pressure and damage to the brake system
- Must be used with hand master cylinder
- Outlet M10x1
- CNC Machined from solid
- For DOT4 brake fluid OR MIL (on demand)
- Anodized for corrosion resistance



Smaller than a marker



HZA01-HZA02
HZA03-HZA04

P/N	DESCRIPTION	Weight g	Brake fluid	Price
HZA04	Ultralight pressure limiter 25 bar	65	DOT4	85
HZA01	Ultralight pressure limiter 35 bar	65	DOT4	85
HZA02	Ultralight pressure limiter 45 bar	65	DOT4	85
HZA03	Ultralight pressure limiter 60 bar	65	DOT4	85

BRAKE SCHEMATICS with ultralightweight pressure limiter

Symmetrical braking on two wheels (hand master cylinder + limiter)

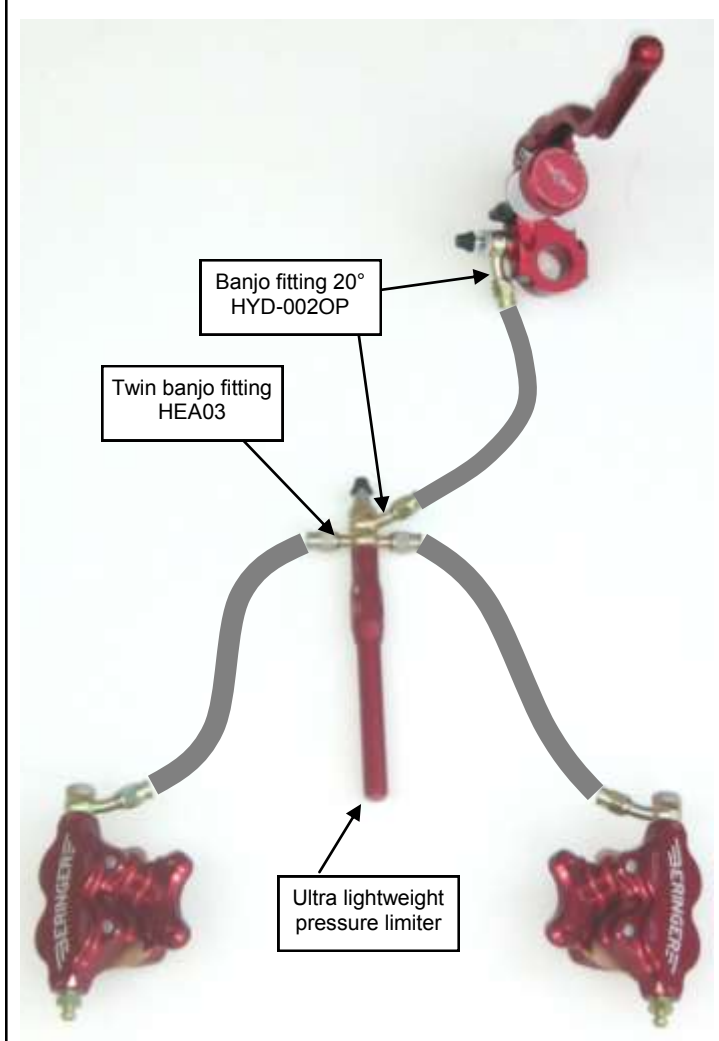

Braking on one wheel (master cylinder cable operated + limiter) (glider)

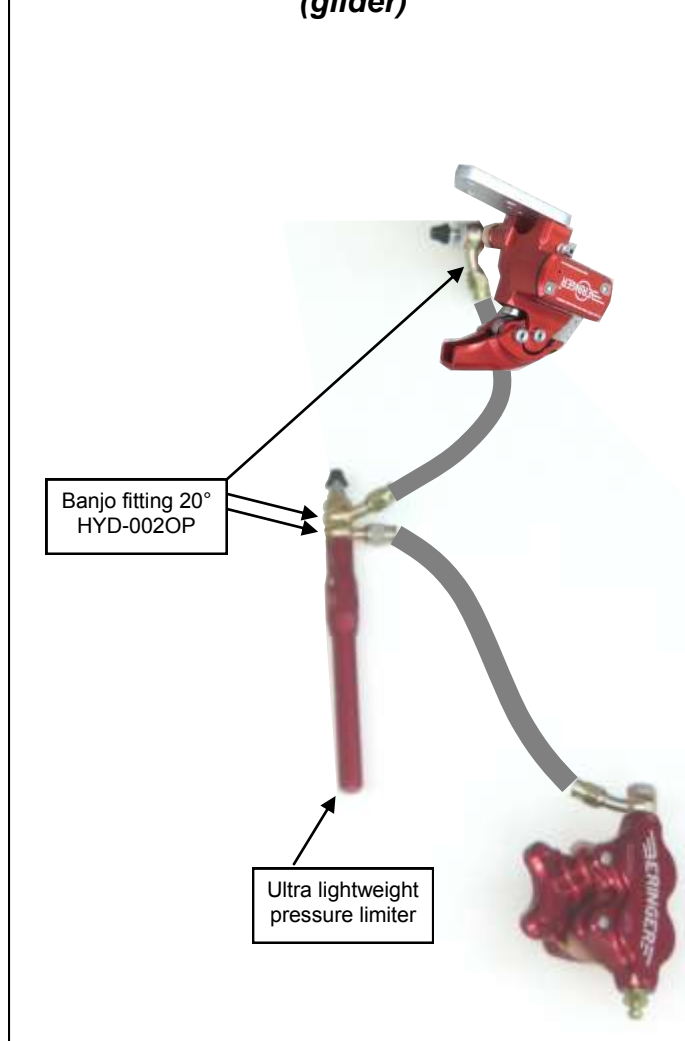

Many accidents occurring on the ground are due to a bad control of the brakes

Avoid all these risks with the BERINGER ALIR on your aircraft

The BERINGER ALIR system improves the control of the brakes and helps the pilot to control the brakes.

This Anti-skid in Line Regulator allows the control of the direction on the ground with differential braking. It avoids wheel locking and risk of nose over when applying full effort on the braking pedals.

It reduces the stopping distance.

The BERINGER ALIR system is included in most wheel & brake kits.

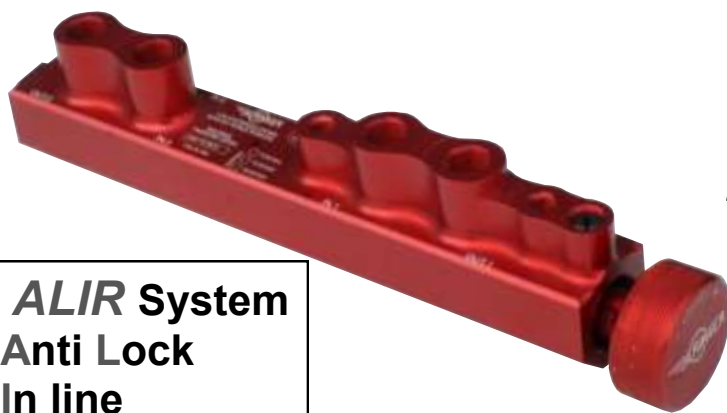

A real advance in terms of safety

**ALIR System
Anti Lock
In line
Regulator**

ALIR PRESSURE REGULATOR allowing a +/- 1 bar maximum reference pressure and an equipressure left-right

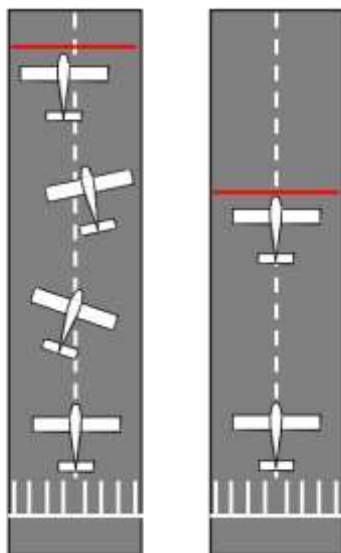

Without ALIR With ALIR

The ALIR system allows the control of the direction on the ground with differential braking.

The system can be installed on certain old aircraft.

EMERGENCY BRAKING : comparison:

- Blue curve: with ALIR: the pilot applies full braking without any control (similar to a car ABS)
 - Red curve: without ALIR: no regulation, the pilot must control the braking
- (in both cases, conditions are the same: same plane, same brakes)
Weight of the aircraft: 1200 kg, braking speed: 70 Kt

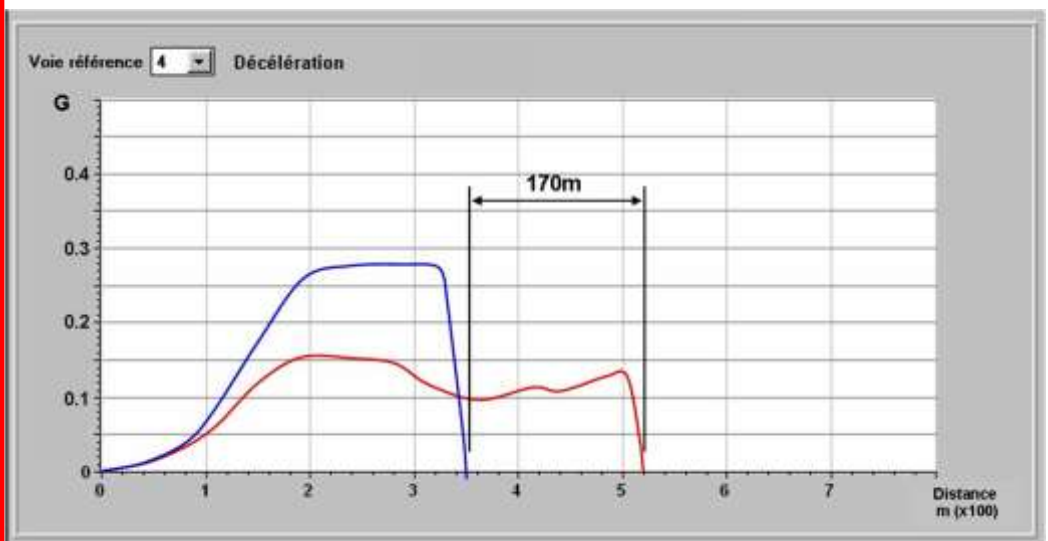

Nota: BERINGER brake pads used in the ALIR system have a friction coefficient that increases with the temperature allowing an increase of the deceleration when the lift decreases on the wings.

ANTI-SKID - REGULATOR - PARKING VALVE

ALIR : In-line BALANCED ANTI-LOCK REGULATOR

Installs in-line; regulates in case of emergency overpressure

- Prevents nose over and improves safety
- Low hysteresis
- Adjustment range: 10 to 40 bars (or 20 to 50 bars, with thumbwheel)
- Machined from solid on CNC
- For DOT4 **OR** MINERAL (MIL) brake fluid
- 2 inputs, 2 outputs (thread: M10x1)

ALIR

PATENTED



HCA02 - HCA12



P/N	DESCRIPTION	weight g	brake fluid	Price
RE-001E	In-line balanced anti-lock regulator 10 to 40 bar	330	DOT4	133
RE-001N	In-line balanced anti-lock regulator 20 to 50 bar	330	MINERAL	133

PARKING BRAKE VALVE

Available for DOT4 **OR** MINERAL (MIL) brake fluid

- Open/close quarter turn lever operated
- CNC machined from billet, red anodized
- Max. input pressure: 1500PSI (100 bar)
- Optimized for long life
- 100% protected from corrosion: anodized coating and stainless steel components



FP-003N



HVA

P/N	DESCRIPTION	Weight g	Outlet port	brake fluid	Price
FP-001	Parking brake valve	126	-3 Flare (3/8x24)	E or N	201
FP-001.1	Parking brake valve	126	-3 Flare (3/8x24)	E or N	201
HVA02	Parking brake valve	126	-4 Flare (7/16x20)	E or N	201
FP-003	Parking brake valve	126	-4 Flare (7/16x20)	E or N	201

DIFFERENTIAL BRAKING SYSTEM SCHEMATIC

Differential braking system with in-line balanced anti-lock regulator (anti-skid & in-line braking) and parking brake valve
(master cylinders are mounted in serie)

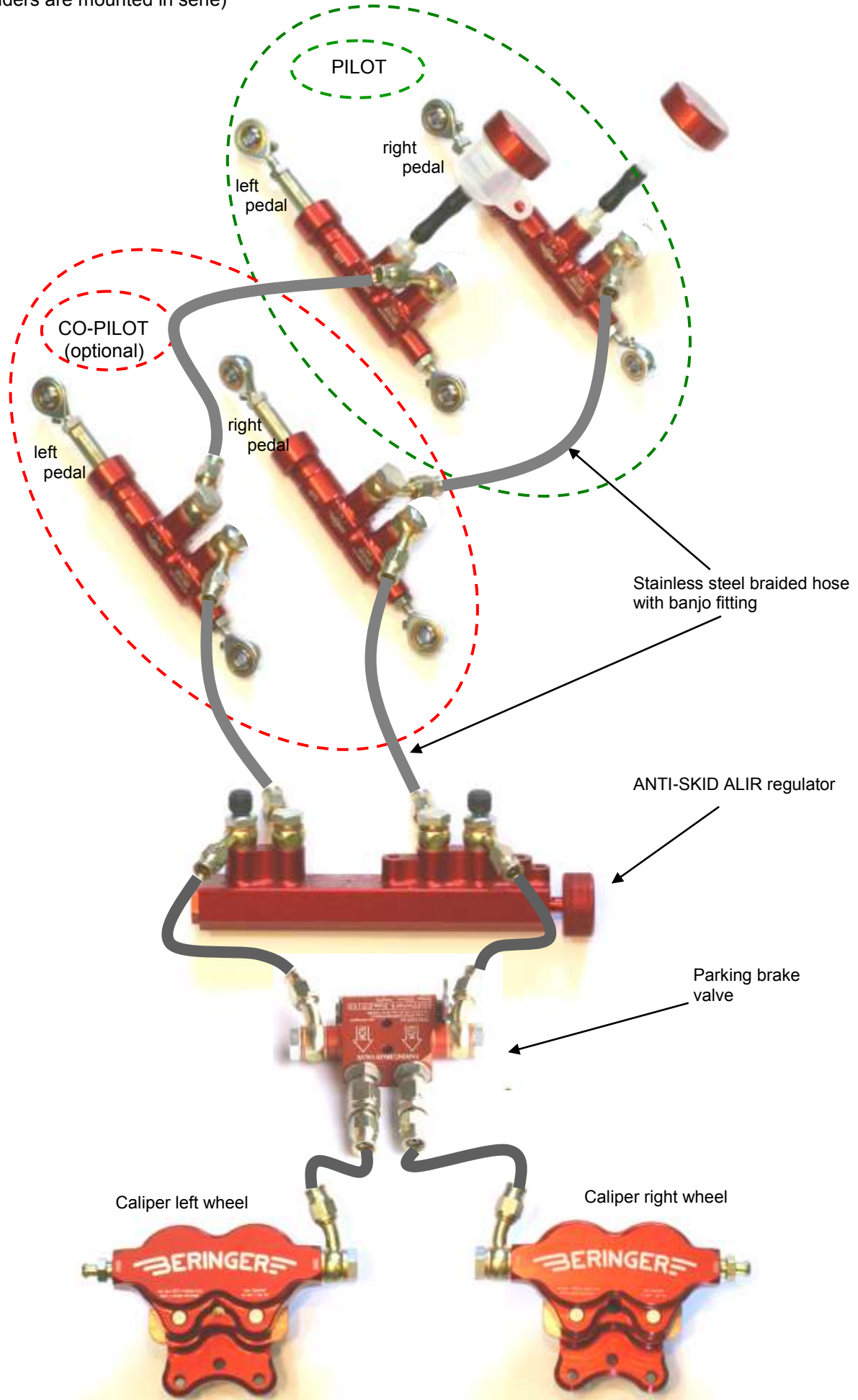

HOSE - HOSE FITTINGS - TO BE SCREWED

SCREW IT YOURSELF: You order brake hose and brake fittings separately and you follow the «assembly instructions» delivered with the parts.

BERINGER Brake hose is stainless steel braided with PTFE inner tube and stainless steel fittings

- Provides consistent brake pedal pressure without spongy feeling
- Flexibility allows landing gear leg movements and avoids leakage that appears with hardline tube.
- Ends can be straight fittings, female concave seat: 7/16x20 or 3/8x24 (steel plated or stainless)
- Maximum pressure 3000 PSI - strength pressure 9000PSI

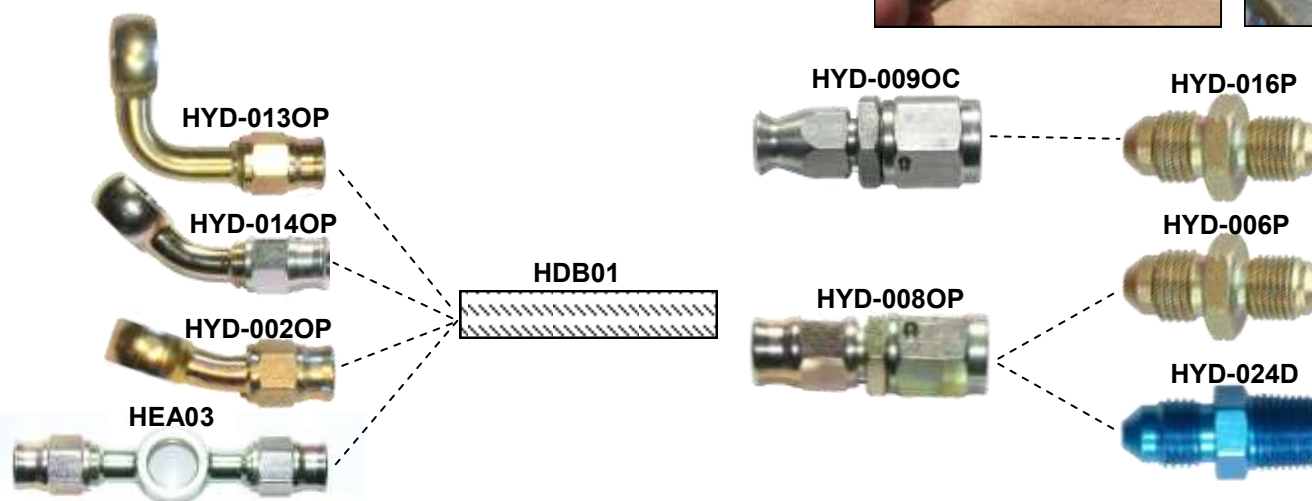
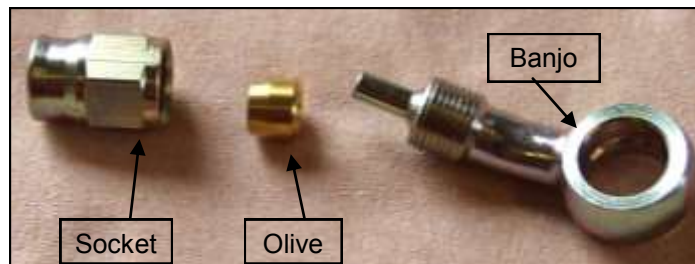

P/N	DESCRIPTION	Price
HOSE Ø 6,7mm and FITTINGS		
HDB01B	Stainless steel brake hose diam 1/4" (price per m)	10,30
HYD-002OP	Banjo fitting 20°	9,06
HYD-014OP	Banjo fitting 45°	9,06
HYD-013OP	Banjo fitting 90°	18,13
HEA03	Twin Banjo	34,61
HYD-008OP	Straight fitting. male M10x1	13,39
HYD-016P	Brake adaptor Metric M10x1 / 7/16x20	9,06
HYD-006P	Brake adaptor Metric M10x1 / 3/8x24	9,06
HYD-024D	Adaptor 3/8" UNF - 1/8 NPTF	7,21
HYD-009OC	Straight fitting, female concave seat 7/16x20 (stainless)	37,90
HOSE Ø 5,2mm and FITTINGS		
HDB02B	Stainless steel brake hose diam 0.2" (price per m)	19,57
HEA13	Banjo fitting 20° Ø 5.2mm stainless	30,39
HEA14	Straight fitting 3/8x24 Ø 5.2mm stainless	30,39
OTHER PARTS and FITTINGS		
HEA12	Spare Olive for Ø 6.7mm hose	2,47
HEA16	Spare Olive for Ø 5.2mm hose	2,47
HEA15	T fitting	25,75
HYD-005B	Copper seal	0,41
HYD-003P	Banjo bolt M10x100	3,09
HYD-011D	Fitting for rubber hose (connection to reservoir)	11,95
HDA01	EPDM hose for reservoir. specific DOT4 brake fluid - per m	4,20
ZGA01	Cushioned tube clamps for stainless steel hose (batch 10 clamps)	7,57
HEA11	Bulkhead fittings	16,50

HYD-005B



HYD-003P



HYD-011D



HEA12



ZGA01



HOSE ASSEMBLY - ASSEMBLED BY BERINGER

WE ASSEMBLE THESE HOSES AND FITTINGS and WE DELIVER THEM READY TO INSTALL.

Choose your fittings, your length and order your brake hose assembly ready to use. Do not hesitate to contact us when you will choose the fittings, we will help you.

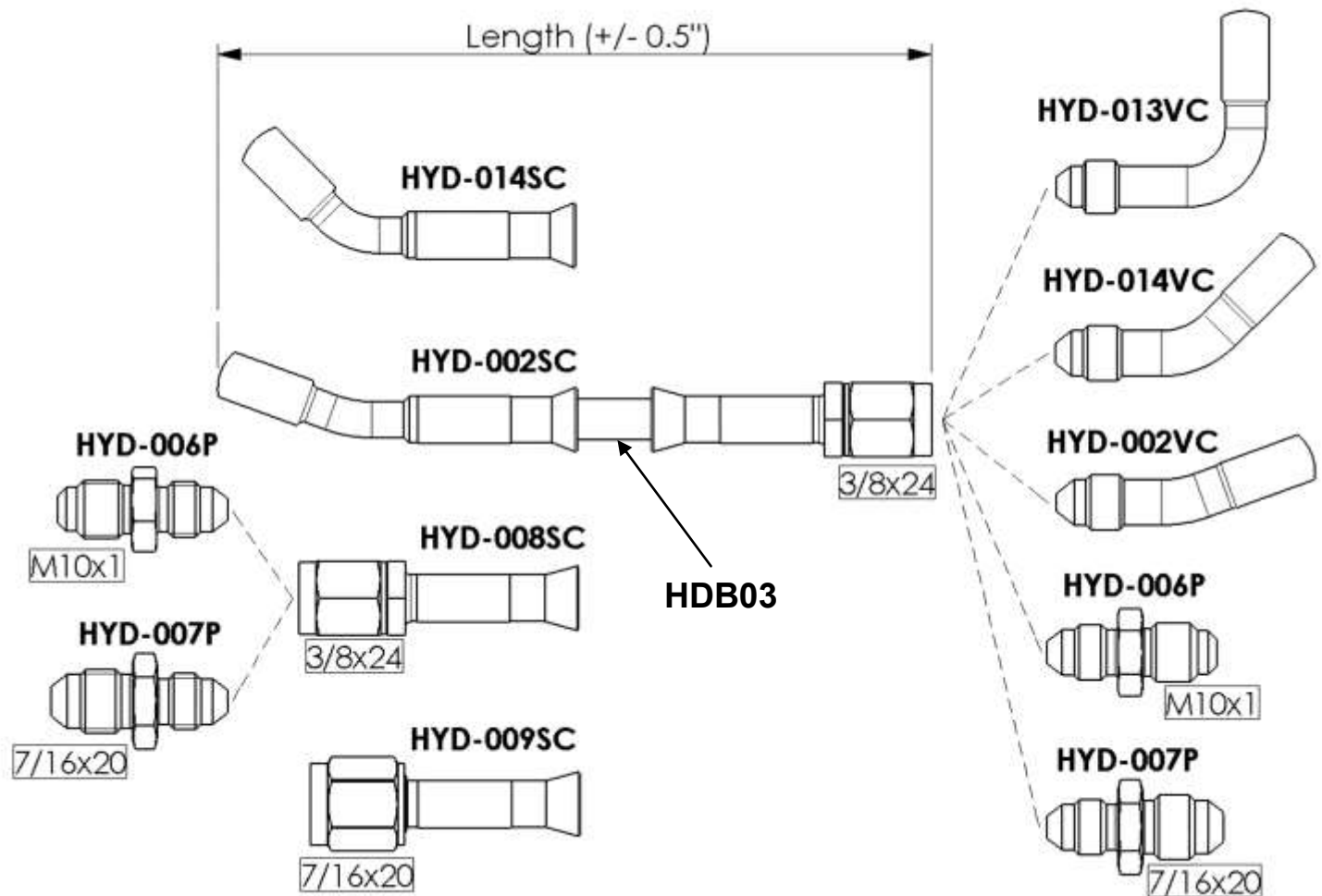

P/N	DESCRIPTION	Price
HOSE Ø 7,5mm and FITTINGS		
HDB03B	Stainless steel brake hose diam 0.29" (price per m)	10,30
HYD-013VC	Banjo fitting 90° - 3/8x24	14,42
HYD-014VC	Banjo fitting 45° - 3/8x24	13,39
HYD-002VC	Banjo fitting 20° - 3/8x24	9,06
HYD-006P	Adapter M10x1 / 3/8x24	9,06
HYD-007P	Adapter 3/8x24 / 7/16x20	8,24
HYD-014SC	Banjo fitting 45°	13,39
HYD-002SC	Banjo fitting 20°	9,06
HYD-008SC	Straight fitting 3/8x24	15,45
HYD-009SC	Straight fitting 7/16x20	25,75
OTHER PARTS and FITTINGS		
HYD-005B	Copper seal	0,41
HYD-003P	Banjo bolt M10x100	3,09
HYD-011D	Fitting for rubber hose (connection to reservoir)	11,95
HDA01	EPDM hose for reservoir, specific for DOT4 brake fluid - per ft	4,20
ZGA01	Cushioned tube clamps for stainless steel hose (batch of 10 clamps)	7,57
HEA11	Bulkhead fittings	16,50

HYD-005B



HYD-003P



HYD-011D



ZGA01



SPARE PARTS

for BERINGER WHEELS

The O-Ring seals between the two parts of the wheels **must be changed at each tire changing.**

All prices are **UNIT PRICES**

Spare part Designation	P/N	Packaging	4" wheels			5" wheels					6" wheels						11.00-12	8.90-12.5			
			3.50-4	5.00-4	3.50-4	5.00-5	5.00-5 HE	4.00-5	4.00-5 HE	5.00-5	4.00-5	4.00-6 SL	6.00-6 HE	6.00-6 SL	6.00-6 SL US	6.00-6 LE			6.00-6 HE	4.00-6 SL	6.00-6 SL
			RF-013	RA-001	RA-003	RF-002	RF-005	RF-007	RF-012	RA-002	RA-011	RF-004	RF-006	RF-009	RF-014	RF-015			RA-005	RA-009	RA-010
Wheel O-Ring	JNT-007N	4																	22.5		
	J-JTR-009N	20																	2.45		
	J-JTR-016N	2																		36.5	
	J-JTR-006N	6				2.5	2.5	2.5	2.5	2.5	2.5										
	J-JTR-007N	6										2.5	2.5	2.5	2.5	2.5	2.5	2.5	2.5		
	J-JTR-019N	3	2.5		2.5																
Valve	A-001	5	10		10	10	10	10	10	10	10	10	10	10	10	10	10	10		10	
Valve O-Ring	J-JTR-017N	10	1.05		1.05	1.05	1.05	1.05	1.05	1.05	1.05	1.05	1.05	1.05	1.05	1.05	1.05	1.05		1.05	
Wheel clips	CLP-003L(B)	30																	8.17		
	CLP-003R(B)	30																	8.17		
	CLP-002(C)	20	1.9			1.9	1.9	1.9	1.9												
	CLP-001(B)	20										1.5			1.5	1.5					
	CLP-004(A)	20									1.5		1.5	1.5			1.5	1.5			
Clip screw	V-CHC-010	100																	0.51		
	V-CHC-005	50	0.35			0.35	0.35	0.35	0.35			0.35	0.35	0.35	0.35						
Wheel assy screw	V-CHC-009	50													1.46				1.46	1.46	
	V-CHC-001	8		3				3	3		3										
	V-CHC-003	8				2.9	2.9			2.9											
	V-CHC-004	16										2.9				2.9					
	V-CHC-008	8									2.9		2.9	2.9				2.9	2.9		
	V-CHC-015	10	2.9		2.9																



All prices are **UNIT PRICES** quoted in euro without tax

The certified parts are delivered with Form1 (10€ per P/N; 30€ flatrate over three P/N)

OLD TYPE 3 part-WHEELS : spare wheel O-ring and clips

Spare part designation	P/N	Packaging	4.00-5	5.00-5	4.00-6	6.00-6	Classic 4.00-6 6.00-6		EA-03 reinforced caliper
			JA-x2 JB-x2	JA-x1 JB-x2	JAA02 JBA02	JAA01 JBA01	JAD01-JAD02 JBD01-JBD02		
Wheel O-ring	KDF01	2 (set for one wheel)	8.80		8.80		8.80		
	KDF02	2 (set for one wheel)	8.80		8.80		8.80		
	KDF02C	2 (set for one wheel)	8.80		8.80		8.80		
Wheel clips	KCA01	10 left + 10 right (warning: some old 5 inch wheel have new clip type)	21		21		21		
Brake pads	ZEA02	2 (for one caliper)	21		21		21		51.50

SPARE PARTS

for BERINGER BRAKE CALIPERS

All prices are **UNIT PRICES**

	P/N	Packaging	EA-001	EA-002	EA-002.2	EA-003	EA-003.2	EA-003.3	EA-003.4	EA-003.5	EA-004	EA-006	EA-007 EA-007.1	EA-009
Brake disc	DSC-011(B)	2	454											
	DSC-008(A)	2		59										
	DSC-008.2(A)	2			109								109	
	DSC-009(A)	2				89								
	DSC-009.3(A)	2						129	129		129			
	DSC-009.4	2								184				
	DSC-013(A)	2												56
	DSC-014	2					129							
	DSC-006(A)	2										56		
Brake pad	PQT-003(A)/004(A)	1 pair										36		36
	PQT-008(B)	4	122.5											
	PQT-009(A)	2		27	27		27						27	
	PQT-010(A)	2				29		29	29		29			
	PQT-010(A)	4								29				
Brake assy screw	V-CHC-011	20	4.1											
	VIS-003(A)	6		4.5	4.5	4.5					4.5		4.5	
	VIS-006(A)	6						4.50	4.5					
	VIS-002(A)	6										4.5		4.5
	VIS-008	6								4.50				
	VIS-015	3					4.50							
	V-CHCB-001	3										4.5		
Bleeding screw	HYD-001P	10	7	7	7	7	7	7	7	7	7	7	7	



All prices are **UNIT PRICES** quoted in euro without tax

The certified parts are delivered with Form1 (10€ per P/N; 30€ flatrate over three P/N)

BRAKE DISCS for ROBIN DR400

- Designed and produced following the ADOA et POA (PART21G) agreement
- High resistance CRO-MO steel
- Fully machined on CNC
- Stabilizing heat treatment to limit heat distorsion
- Anticorrosion coating for easy running

CRO-MO alloy

**longer life
maintenance reduced**



DESCRIPTION	P/N	Unit Price
Brake disc for ROBIN DR400 <u>delivered with EASA Form1</u>	AV-ROB-001	195

TOOLS - BLEEDER - BRAKE FLUID

P/N	DESCRIPTION	Unit price	
OPA01	Tire changing tool for 5" wheels	84	
OPA02	Tire changing tool for 6" wheels	99	
OHT01	Torquing tool for M25x1.5 nut	54	
OHT02	Metric tool kit	9	
ONA01	Spray lubricant Tire Up	26	
ONB01	Spray anti-puncture	21	
ONC01	Brake bleeder tank kit	75	
HJA01	High performance Brake fluid DOT4	0.33L	17
HJA02	High performance Brake fluid DOT5 Silicone base DOT5 cannot be mixed with DOT4.	0.33L	24
HJA03	High performance Mineral brake fluid MIL-PRF-87257	1 Gallon	35

BERINGER® TOOL for tire changing

Specific tire change tool for BERINGER® wheels with conical aluminum spacer: eases mounting of tire on wheel half.

- Plywood flanges steady tire while positioning second wheel half with the O-ring.
- Includes: Plywood flanges, bolts with butterfly nut and conical aluminum spacer



BRAKE FLUIDS

- High performance DOT4 brake fluid with dry boiling point at 440°F minimum meets FMVSS 116/DOT4 specifications. DOT4 is yellow colored and it is **not** compatible with brake system designed for mineral base fluids (see explanation page 6)
- Mineral brake fluid: HIGH PERFORMANCE following spec. MIL-PRF-87257



METRIC TOOL KIT



BRAKE BLEEDER TANK necessary for an easy bleeding operation

helps the bleeding by sending the brake fluid under pressure in the line through the calipers. Delivered with manometer, hose and small bottle to collect the extra fluid.

TIRE LUBRICANT

Spray of professional liquid soap

SPRAY ANTI-PUNCTURE

to spray into the tire in case of puncture



Small bottle to collect the extra fluid



Bleeder tank

Tribute to BERINGER 2015 Champions...



David Robinson
Pilot "Sport 92"
1st Place
Silver Sport Class 2015
Reno Air Races
on Lancair
Copyright McCallister

Olivier MASUREL
2015 WAG Champion
With Vendée Sports Aériens
Copyright Vendée Sports Aériens



Kirby CHAMBLISS
Air show performer
Red Bull Air Race Pilot
Copyright Kirby Chambliss

Tribute to BERINGER 2015 Champions...



Bob Carlton
Airshow performer
on Jet powered Sailplane
Copyright Véronique Béringer

Mike Goulian
Edge 540
American pilot
Air show performer
Red Bull Air Race Pilot
Aviation author
copyright Mike Goulian



Nicolas Ivanoff
Edge 540
Airshow Performer
Red Bull Air Race Pilot
Nicolas helped BERINGER to
develop the wheel and brake
kits for the Edge and the Extra
330.
Copyright Véronique Béringer



They have chosen BERINGER as original equipment...

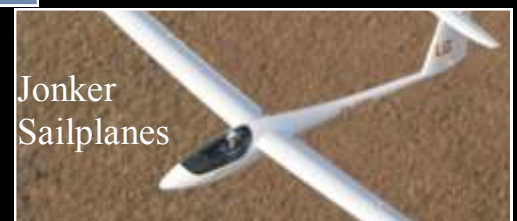

They have chosen **BERINGER** as original equipment



And many more ...



BERINGER AERO France
Aéropôle, FR-05130 Tallard
Phone +33 (0) 4 92 20 16 19
Fax +33 (0) 4 92 52 69 66
contact@beringer-aero.com
sales@beringer-aero.com

BERINGER AERO Worldwide
Through the official **SERVICE CENTER** network

BERINGER AERO USA
4118 N, Nashville
Chicago, IL 60634
Phone (708) 667 7891
us.sales@beringer-aero-usa.com



www.beringer-aero.com